

# The RADIO Constructor

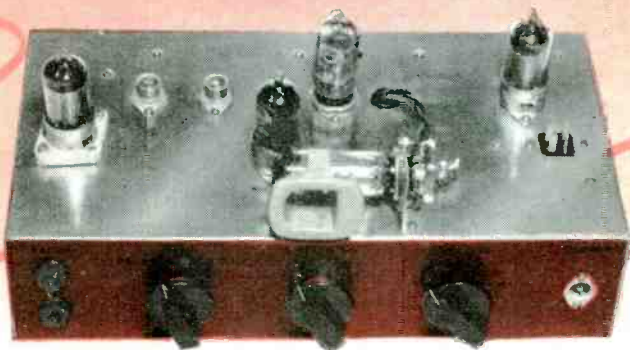

RADIO · TELEVISION · AUDIO · ELECTRONICS

## The MULLARD Tape Amplifier "Type C"



LATEST VERSION OF THIS  
POPULAR UNIT WITH  
PUSH-PULL OUTPUT

Included in this issue

- A SENSITIVE TRANSISTOR RECEIVER
- FM FACILITATED
- REMOTELY SWITCHED TV PRE-AMPS
- A VERSATILE AUDIO FREQUENCY OSCILLATOR
- UNDERSTANDING TELEVISION, Part II
- POWER UNIT WITH A DIFFERENCE

DATA  
Publications 19

# THE MODERN BOOK CO

**A Beginner's Guide to Television.**  
By F. J. Camm. 7s. 6d. Postage 6d.

**TV Fault Finding.** A Data Publication.  
5s. Postage 6d.

**Oscilloscope Equipment.** By D. W. Easterling. 5s. Postage 4d.

**Elements of Tape Recorder Circuits.**  
By H. Burstein and H. C. Pollak. 23s. Postage 9d.

**The Radio Amateur's Handbook.**  
By A.R.R.L. 32s. 6d. Postage 1s. 9d.

**World Radio Handbook for Listeners.** 1958 ed. 13s. 6d. Postage 1s.

**Radio Valve Data.** 6th Ed. Compiled by "WVW". 5s. Postage 9d.

**Quality Amplifiers for A.C. Mains.**  
Data Publications. 4s. 6d. Postage 4d.

**Electronic Puzzles and Games.** By M. Mandl. 15s. Postage 8d.

**An Electronic Organ for the Home Constructor.** By A. Douglas. 15s. Postage 9d.

**Electronic Hobbyists' Handbook.**  
By R. P. Turner. 20s. Postage 9d.

**High Fidelity Sound Reproduction.**  
By E. Molloy. 20s. Postage 1s.

**Basic Mathematics for Radio and Electronics.** By F. M. Colebrook and J. W. Head. 17s. 6d. Postage 1s.

**Transistor Circuits.** By R. P. Turner. 22s. Postage 9d.

We have the Finest Selection of British and American Radio Books in the Country  
*Complete catalogue 6d.*

**19-23 PRAED STREET (Dept RC) LONDON W2**

Telephone PADDington 4185

RADIO SOCIETY OF GREAT BRITAIN



## **RADIO HOBBIES EXHIBITION**

**Royal Horticultural Old Hall · Vincent Square · London SW1**

**WEDNESDAY to SATURDAY — NOVEMBER 26th to 29th — 11 a.m. to 9 p.m.**

ADMISSION 2/-

HOME CONSTRUCTION  
DO-IT-YOURSELF  
FEATURES

Kits of Parts to BUILD . . . .  
Receivers, Transmitters, Televisors,  
Hi-Fi Amplifiers, Test Gear, Tape  
Recorders, and Transistor Equipment

### **First Public Colour Television Show**

Live Radio Station    Army, Navy and Royal Air Force Displays

**WIN A WORLD FAMOUS £400 RACAL COMMUNICATIONS RECEIVER** See this month's entry card

FURTHER DETAILS FROM P. A. THOROGOOD G4KD 35 GIBBS GREEN EDGWARE MIDDXX

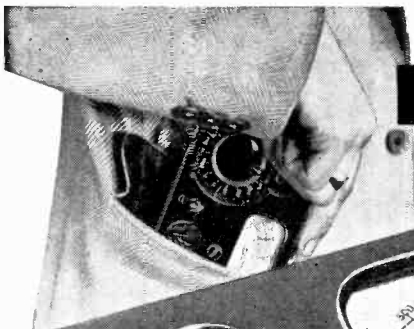

**TO FIT THE POCKET**



**TO FILL THE BILL**

**19 Ranges**

<b>D.C. Voltage</b>	<b>A.C. Voltage</b>
0—100mV	0—10V
0—2.5V	0—25V
0—10V	0—100V
0—25V	0—250V
0—100V	0—1000V
0—250V	
0—1000V	

<b>Resistance</b>
0—20,000Ω
0—2MΩ

<b>D.C. Current</b>
0—100μA
0—1mA
0—10mA
0—100mA
0—1A

**Sensitivity**  
 10,000 Ω/V on D.C. voltage ranges  
 1,000 Ω/V on A.C. voltage ranges

**Accuracy**  
 3% of full scale value on D.C.  
 4% of full scale value on A.C.

*To meet special requirements, instruments can be supplied to a higher degree of accuracy for a small additional charge.*

This splendid AVO Instrument has been developed to meet a definite demand for a sturdy pocket-size multi-range test meter at a modest price, suitable for use on modern electronic apparatus as well as for radio and television receivers, motor vehicles, and all kinds of domestic appliances and workshop equipment.

Readings are obtainable quickly and easily on a very open scale, and range selection is by means of a robust clearly marked rotary switch of the characteristic Avometer type. Measurements of A.C. and D.C. Voltage, D.C. Current and Resistance are made by means of only two connection sockets.

**THE MULTIMINOR**

List Price: **£9 : 10s.**

complete with Test Leads and Clips  
 Leather Case if required 32/6

Size: 5½ x 3½ x 1½ inches  
 Weight: 1lb approx.

Write for fully illustrated pamphlet



**AVO Ltd. AVOCET HOUSE · 92-96 VAUXHALL BRIDGE ROAD · LONDON · SW1**

Telephone VICToria 3404 (9 lines)

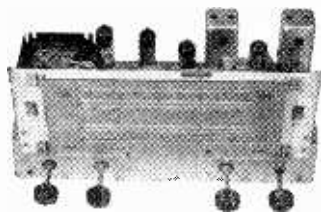

### 1958 RADIOGRAM CHASSIS

THREE WAVEBANDS FIVE VALVES  
 S.W. 16 m.-50 m. LATEST MULLARD  
 M.W. 200 m.-550 m. ECH42, EF41, EBC41,  
 L.W. 800 m.-2,000 m. EL41, EZ40  
 12 month Guarantee. A.C. 200/250V, 4-way switch.  
 Short-Medium-Long-Grm. A.V.C. and negative feed-  
 back. 4.2 watts. Chassis 13 1/2" x 5 1/2" x 2 1/2". Glass dial  
 12 1/2" x 5 1/2" horizontal or vertical 10" x 4 1/2". 2 pilot lamps.  
 Four knobs, walnut or ivory, aligned and calibrated.  
 Chassis isolated from mains. Immediate delivery.

**BRAND NEW £9.10 Carr. 4/6**

TERMS: Deposit £5.50 and 5 monthly payments of £1  
 MATCHED SPEAKERS: 8" 17/6, 10" 25/-, 12" 30/-

### GARRARD 4-SPEED SINGLE RECORD PLAYER 4SP

★ **£8 AUDIO PERFECTION** ★ POST FREE

Designed to play 16, 33, 45, 78 r.p.m. Records, 7",  
 10", 12". Lightweight Xtal pick-up, GC2 turnover  
 head, two separate sapphire styli. Standard and L.P.

### BUILD THIS REPRODUCER BARGAIN

#### SPECIAL SINGLE PLAYER KIT

COLLARO 4-speed Gram-Pick-up Unit **£4.12.6**  
 Handsome portable case 17 1/2" x 13 1/2" x 7" **£2. 5.0**  
 Ready-built 3 watt amplifier with two valves  
 and 7" elip. speaker, printed circuit **£3.12.6**

All available separately

**£9.15.0** complete kit post free

### I.F. TRANSFORMERS 7/6 pair

465 kc/s slug tuning miniature can 2 1/2" x 1" x 1".  
 High Q and good band width. By Pye Radio. Data  
 sheet supplied.

Wearite M800 Midget I.F.S. 465 kc/s 12/6 pair  
 Wearite 550 Standard I.F.S. 465 kc/s 12/6 pair

### New boxed VALVES 90-day Guarantee

1R5	8/6	6K8	8/6	EAS0	1/6	EZ81	11/6
1S5	8/6	6L6	10/6	EABC8010/6		E1148	1/6
1T4	8/6	6Q7	10/6	EB91	6/6	HABC80	12/6
2X2	2/6	6SA7	10/6	EBC33	8/6	HVR2A	7/6
3S4	8/6	6SJ7M	10/6	EBC41	10/6	MU14	10/6
3V4	8/6	6SN7	8/6	EBF80	10/6	P61	6/6
5U4	8/6	6V6G	7/6	ECC84	12/6	PCC84	12/6
5Y3	8/6	6V6GT	8/6	ECF80	11/6	PCF80	11/6
5Z4	10/6	6X4	7/6	ECF82	11/6	PCF82	11/6
6AM6	8/6	6X5	7/6	ECH42	10/6	PCL82	11/6
6B8	5/6	7S7	10/6	ECL82	12/6	PEN25	6/6
6BE6	7/6	12AH8	10/6	EF39	7/9	PL82	10/6
6BH6	10/6	12AT7	10/6	EF41	10/6	PY80	10/6
6BV6	10/6	12AU7	9/6	EF50	5/6	PY81	10/6
6CH6	10/6	12AX7	9/6	Equip.		PY82	10/6
6D6	7/6	12BE6	9/6	EF50	8/6	SP61	5/6
6F6	7/6	12K7	8/6	Sylv.		UBC41	10/6
6H6	3/6	12Q7	8/6	EF80	10/6	UCH42	10/6
6J5	6/6	35L6	9/6	EF92	5/6	UF41	10/6
6J6	7/6	35Z4	9/6	EL32	5/6	UL41	10/6
6J7	8/6	80	10/6	EL84	10/6	UY41	10/6
6K6	6/6	807	6/6	EY51	12/6	U22	10/6
6K7	5/6	954	1/6	EZ40	10/6	X79	10/6

### C.R.T. ISOLATION TRANSFORMERS

For Cathode Ray Tubes having heater-cathode short circuit and for C.R. Tubes with falling emission.  
**Type A.** Low leakage windings. **Optional 25% and 50%** boost on secondary: 2V, or 4V, or 6.3V, or 10.3V, or 13.3V, with mains primaries, 12/6

**Type B.** Mains input. Low capacity. Multi-output 2, 4, 6.3, 7.3, 10 and 13V. Boost 25% and 50%. This transformer is suitable for all TV tubes. 21/- each

**Type C.** Low capacity transformer for 2V tubes with falling emission. Mains input. Output 2, 2 1/2, 2 1/2, 3V at 2A, 17/6 each

**RESISTORS.** Preferred values. 20% 10 ohms to 10 meg, 1/2W 4d., 1/2W 4d., 1W 6d., 1 1/2W 8d.

**HIGH STABILITY.** 1/2W 1%, 2/-; All preferred values 100Ω-10MΩ. Ditto 5% 100Ω-5MΩ 9d. each

5 watt } **WIRE-WOUND RESISTORS** { 1/3  
 10 watt } 25 ohms-10,000 ohms { 1/6  
 15 watt } { 2/-  
 15,000 ohms-50,000 ohms, 5W, 1/9; 10W, 2/3

**WIRE-WOUND POTS** 3W Lab. Colvern, etc.  
 Pre-set min. TV type. Standard size Pots, 2 1/2".  
 Knurled slotted knob. Spindle, high grade. All  
 All values 25 ohms to 30k, 5/6; 100k, 6/6  
 3/- each. 50k, 4/-  
 Ditto Carbon Track 50k W/W EXT. SPEAKER  
 to 2 Meg, 3/- CONTROL 10Ω, 3/-

### MAINS TRANSFORMERS

**STANDARD.** 250-0-250, 80mA, 6.3V tapped 4V 4A. 22/6  
 Rectifier 6.3V 1A tapped 5V 2A and 4V 2A 22/6  
 Ditto 350-0-350 22/6  
**MINIATURE.** 200V 20mA, 6.3V 1A 10/6  
**MIDGET.** 220V 45mA, 6.3V 2A 15/6  
**SMALL.** 220-0-220, 50mA, 6.3V 3A 17/6  
**STANDARD.** 250-0-250, 65mA, 6.3V 3.5A 17/6  
**HEATER TRANS.** 200/250V, 6.3V 1 1/2A 7/6  
 Ditto, tapped sec. 2, 4, 6.3V 1 1/2A 8/6  
 Ditto, sec. 6.3V 3A 10/6  
**Mullard "510" Mains Transformers** 38/6

**O/P TRANSFORMERS.** Heavy duty 50mA, 4/6.  
 Multi-ratio push-pull, 7/6. Miniature 3V4, etc., 4/6.  
 Small pentode, 4/6. Hygrade push-pull 7 watts, 15/6.  
 Mullard "510" 6k or 8kΩ, 30/-

**L.F. CHOKES** 15/10H 60/65mA, 5/-; 10H, 85mA, 10/6; 20/15H, 120/150mA, 12/6; 5H, 250mA, 15/-

### CRYSTAL MIKE INSERT by Acos, 6/6

Precision engineered. Size only 3/4" x 1 1/4"  
**ACOS CRYSTAL DESK MIKE** 33/2 35/-

**ALADDIN FORMERS** and cores. 1/2" 8d., 3/8" 10d.,  
 0.3" FORMERS 5937/8 and cans TV1/2. 3/8" sq. x 2 1/2"  
 and 3/8" sq. x 1 1/2", 2/- complete with cores

**SLOW MOTION DRIVES.** Epicyclic ratio 6-1, 2/3  
**TYANA.** Midget Soldering Iron. 200/250V or 230/  
 250V, 16/9. **SOLON MIDGET IRON,** 25W, 24/-

**MAINS DROPPERS.** 3" x 1 1/2". Three adjustable sliders,  
 0.3A 750 ohms, 4/3; 0.2A 1,000 ohms, 4/3

**LINE CORD.** 0.3A 60 ohms per foot, 0.2A 100 ohms  
 per foot, 2-way, 6d. per foot; 3-way, 7d. per foot

**MIKE TRANSF.** 50:1, 3/9; 100:1, potted, 10/6

**LOUDSPEAKERS.** P.M. 3 ohm. 2 1/2" and 5", 17/6;  
 6" x 4" Rola, 18/-; 4" Hi-Fi Tweeter, 25/-; 8" Plessey,  
 19/6; 6 1/2" Goodmans, 18/6; 10" R.A., 30/-; 12" Plessey,  
 30/-; 10" x 6" R.A., 27/6; 12" Baker 15W 3 ohm or 15  
 ohm models, 105/-; Stentorian HF1012 10" 3 to 15  
 ohms 10W, 99/6

**CRYSTAL DIODES.** G.E.C., 2/-; GEX34, 4/-  
**40 CIRCUITS FOR GERMANIUM DIODES, 3/-**

**TUNING AND REACTION CONDENSERS**  
 100pF, 300pF, 500pF, 3/6 each, solid dielectric

**H.R. HEADPHONES** 4,000 ohms, brand new, 16/6 pr.

**SWITCH CLEANER FLUID,** squirt spout, 4/3 cin

**TWIN GANG CONDENSERS.** 365pF, miniature,  
 1 1/2" x 1 1/2" x 1 1/2", 10/-; 0.0005 standard with trimmers,  
 9/-; less trimmers, 8/-; Midget 7/6; 50pF single, 2/6

## 48-HOUR POSTAL SERVICE

Our written guarantee with every purchase

# RADIO COMPON

Buses 133 or 68 pass door S.R. Stn. Selhurst

**Aluminium Chassis.** 18 s.w.g. Plain, undrilled, with 4 sides, riveted corners and lattice fixing holes. With 2 1/2" sides. 7" x 4", 4/6; 9" x 7", 5/9; 11" x 7" 6/9; 13" x 9", 8/6; 14" x 11", 10/6; 15" x 14", 12/6; 18" x 16" x 3", 16/6

**Volume Controls**

Midget size Long spindles. Guaranteed 1 year. All values 5,000 ohms to 2 Meg. No Switch D.P. Switch 3/- 4/9 Linear or Log Tracks

**80Ω Coaxial Cable**

Semi-air spaced Polythene insulated 1/4" dia. stranded core. Ideal Band III 9d. yd Losses cut 50%

FRINGE QUALITY Air-spaced Coaxial 1/6 yd

**Coaxial Plugs** 1/- **Double Socket** 1/3  
**Sockets** 1/- **Outlet Boxes** 4/6  
**Balanced Twin Feeder**, per yd 6d., 80Ω or 300Ω  
**Twin Screened Balanced Feeder**, 1/6 yd, 80 ohms  
**Trimmers**, Ceramic, 30, 50, 70pF, 9d.; 100pF, 150pF, 1/3; 250pF, 1/6; 600pF, 750pF, 1/9. Philips, 1/- each  
**BLACK CRACKLE PAINT**, Air drying, 3/- tin  
**P.V.C. CONN. WIRE**, 8 colours, single or stranded, 2d. yd. Sleeving 1, 2mm, 2d., 2, 3mm, 3d., 6mm, 5d. yd  
**5" RADIO SCREWDRIVERS**, 6d. each  
**NEON MAINS TESTER SCREWDRIVERS**, 5/3  
**SOLDER RADIOGRADE**, 3 yds 9d., 1lb 2/6  
**Sentercel Rectifiers**, E.H.T. Type Flyback. Voltages: K3/25 2kV, 5/-; K3/40 3.2kV, 7/-; K3/45 3.6kV, 7/6; K3/50 4kV, 8/-; K3/100 8kV, 14/6  
50 cps voltage 30% of above ratings

**Mains Type RM1**, 125V 60mA, 5/-; **RM2** 100mA, 6/-; **RM3** 120mA, 8/-; **RM4** 250V 275mA, 16/-; **RM5**, 20/-  
**Miniature Contact Cooled Rectifiers**, 250V 50mA, 8/6; 250V 85mA, 9/6. **Selenium Rect.** 300V 85mA, 7/6  
**Coils**, Wearite "P" type, 3/- each. **Osamor Midget "O" type**, adj. dust core, from 4/- each. All ranges **Teletron**, L & Med. T.F.R. with reaction, 3/6  
**Ferrite Rod Aerials**, M.W., 8/9; M. & L., 12/6  
**T.R.F. Coils A/HF**, 7/- pair. **H.F. Chokes**, 2/6  
**Speaker Fret**, Gold cloth, 17" x 25", 5/-; 25" x 35" 10/-  
**Expanded metal**, silver, 15 1/2" x 9 1/2", 2/- each; **Tygan**, 4' 6" wide, 10/- ft; 2' 3" wide, 5/- ft. Samples

**SUPERHET COIL PACK 27/6**

Miniature size high Q coils. Short, Med., Long. Gram. switching, with connection diagram. 465 kc/s i.f.

**Condensers**. New stock, 0.001μF 7kV T.C.C., 5/6 ditto 20kV, 9/6; 100pF to 500pF Micas, 6d.; Tubular 500V 0.001 to 0.01μF, 9d.; 0.05, 0.1, 1/-; 0.25, 1/6; 0.5, 1/9; 0.1/350V, 9d.; 0.01/2,000V, 1/9; 0.1/2,000V, 3/6  
**Ceramic Condensers**. 500V 0.3pF to 0.01μF, 10d.  
**Silver Mica**. 10% 5pF to 500pF, 1/-; 600pF to 3,000pF, 1/3; close tolerance (plus or minus 1pF). 1.5pF to 47pF, 1/6; ditto 1/5 50pF to 815pF, 1/9; 1,000pF to 5,000pF, 2/-

**NEW ELECTROLYTICS FAMOUS MAKES**

TUBULAR		TUBULAR		CAN TYPES	
1/350V	2/-	100/25V	2/-	8+16/450V	5/-
2/450V	2/3	8+8/500V	6/-	16+16/450V	5/6
4/450V	2/3	16+16/500V	6/-	6,000μF 6V	6/6
8/450V	2/3	CAN TYPES		32+32/350V	4/6
8/500V	2/9	Clips	3d.	32+32/450V	6/6
16/450V	3/6	16/500V	4/-	64+120/275V	7/6
16/500V	4/-	32/350V	4/-	60+100/350V/11/6	
32/450V	5/6	100/275V	5/6	100+200/275V	
25/25V	1/9	50+50/350V	7/-		10/6
50/25V	2/-	500/12V	3/-		1,000+1,000/6V
50/50V	2/-	2,500/3V	4/-		6/6

**Full Wave Bridge Selenium Rectifiers**, 2, 6 or 12V 1 1/2A, 8/9; 2A, 11/3; 4A, 17/6. Free charger circuit  
**Charger Transformers**. Tapped input 200/250V for charging at 2, 6 or 12V 1 1/2A, 15/6; 2A, 17/6; 4A, 22/6

**12/6 PURETONE RECORDING TAPE** 1,200ft on standard fitting, 7" metal reels. Spare reels 7" metal, 2/3; 5 1/2" plastic, 3/-; 7" plastic, 4/-  
**SUPERIOR** 1,200ft plastic tape, 21/-; 7" plastic reel  
**EMITAPE** 7" Long Play 1,800 ft. 45/-  
**INSTANT** bulk tape eraser, 200/250V a.c., 27/6

**TELETRON MINIATURE "TRANSIDYNE" Superhet Portable**

6 Transistors, T.C.C. Printed Circuit Ferrite aerial, cabinet and all parts. For medium and long wave reception

Our price **£12.19.6** post free



Size 6" x 4" x 1 1/2" Plans and parts list 9d.

**6 GENUINE PYE GOLTOP TRANSISTORS ARE INCLUDED WITH THIS KIT, FOR MAXIMUM RESULTS**

**TRANSISTORS**. Pye Goltop Audio V10/15A, 15/- R.F. 3 Mc/s, V6/R2, 24/- Sub-miniature Electrolytics 5μF 12V, 8μF 6V, 16μF 12V, 25μF 6V, 3/- each

**THE HIGH GAIN BAND III TV PRE-AMP Tunable Channels 8, 9 and 10, Gain 17dB, Cascode Circuit**. Complete kit with ECC84 valve, plans and instructions, 29/6 less power, or 49/6 with power pack. Plans only, 6d. Band I version available for channels 1 to 5, same prices

**Wavechange Switches**. 2 p 2-way, 3 p 2-way, short spindle, 2/6; 5 p 4-way 2 wafers, long spindle, 6/6; 2 p 6-way, 4 p 2-way, 4 p 3-way, long spindle, 3/6; 3 p 4-way, 1 p 2-way, long spindle, 3/6; wave change "MAKITS", 1 wafer, 8/6; 2 wafers, 12/6; 3 wafers, 16/-; 4 wafers, 19/6; 5 wafers, 23/-; 6 wafers, 26/6  
**Toggle Switches**, s.p. 2/-, d.p. 3/6, d.p.d.c. 4/-

**JASON FM TUNER COIL SET, 26/-**, H.F. coil, aerial coil, oscillator coil, two i.f. transformers 10.7 Mc/s, detector transformer and heater choke. Circuit and component book using four 6AM6, 2/-  
**Complete Jason FM Kit**, with valves and Jason superior calibrated dial, £6.15.0, post free  
**Mullard 3-3**. Amplifier ready built, with power socket for tuner, £7.17.6

**Valveholders**. Pax. int. oct., 4d. EF50, EA50, 6d. B12A, CRT, 1/3. Eng. and Amer. 4, 5, 6, 7 and 9 pin, 1/-  
**MOULDED Mazda** and int. oct., 6d., B7G, B8A, B8G, B9A, 9d. B7G with can, 1/6. VCR9/2, 6d. B9A with can, 2/6. Ceramic, EF50, B7G, B9A int. oct., 1/- B7G with can, 1/9; B9A with can, 2/9

**HANDY VOLTMETERS**. 2" Twin Range 0-25V, 0-250V d.c. with leads and leather case, 9/6 each

**TV Fault Finding**. Data Publications 5/- each  
**Radio Valve Guide**. Books 1, 2 or 3 5/- each

**TELETRON 'COMPANION' PRINTED CIRCUIT TRANSISTOR THREE**

**£5.15.0**  
WITH 3 PYE GOLTOP TRANSISTORS



Pocket receiver kit, 4 1/2" x 3" x 1 1/2" with plans, cabinet, all parts and batteries. Fitted speaker reproduces strong local stations on Ferrite Aerial. Distant reception with simple aerial or earth

**NT SPECIALISTS**

**337 WHITEHORSE ROAD WEST CROYDON** *Telephone THO 1665*

& P. 1/-, over £2 post free. C.O.D. 1/6 (Export C.W.O. post extra, no H.P.) **OPEN ALL DAY (Wed. 1 p.m.)**

# PREMIER RADIO COMPANY

B. H. MORRIS & CO (RADIO) LTD

(Dept. R.C.7) 207 EDGWARE ROAD LONDON W2

Also 23 Tottenham Court Road London W1

Open till 6 p.m.  
Saturday

Telephone  
AMB 4033  
PAD 3271



## THE "PETITE" PORTABLE

MAY BE  
BUILT FOR **7 GNS.**  
plus 3/- post & pkg.

Batteries extra  
H.T. 10/- (Type B126) or  
equivalent.  
L.T. 1/6 (Type AD 35) or  
equivalent.

- ★ Size only 8" x 8" x 4½"
- ★ Weight including batteries 5½lb
- ★ 4 valves of the economy type
- ★ Medium and long wave superhet circuit
- ★ High Q frame aerial
- ★ High sensitivity on both wavebands
- ★ Pre-aligned i.f. transformers
- ★ 5" speaker of the latest type
- ★ Automatic on/off switch operated by lid
- ★ Designed in our own laboratory
- ★ Backed by an up-to-date Technical Information Dept.
- ★ Components available separately if desired
- ★ Simple to construct, using normal soldering methods
- ★ Instruction book 1/6

## THE "PETITE" PORTABLE & REPRODUCER

MAY BE  
BUILT FOR **13 GNS.**  
plus 5/- post. & pkg.

Batteries extra: H.T. 10/-  
(Type B126 or equiv.) L.T.  
996, 3/6



45 r.p.m. Single Record Player  
£5.5.0 including P.T.

"Petite" Components  
£5.13.0

Portable Case £2.10.0

- ★ Size 10½" x 9½" x 6"
- ★ Weight including batteries 7lb
- ★ 45 r.p.m. single record player complete with pick-up
- ★ 6V battery operated
- ★ Incorporates pick-up head protection dome and automatic stylus cleaning brush, overall size 7½" x 6" only
- ★ Automatic stop-start
- ★ Completely battery operated
- ★ Attractive two-tone rexine covered case
- ★ Construction simplicity itself
- ★ Components available separately if required
- ★ Instruction Book 1/6

## A COMPLETE RANGE OF PREMIER STEREO EQUIPMENT

Including:

### THE PREMIER DE-LUXE STEREO RECORD PLAYER AMPLIFIER

This is a 4-valve Stereo Amplifier with tone balance, speaker switch and volume control, size 12" long, 5½" high, 3" wide, output of each section is 3½ watts. £8 plus pkg. and post 4/6



De Luxe Portable Cabinet suitable for housing the above Stereo Amplifier with detachable lid which will accommodate an 8" x 5" elliptical speaker, overall size of cabinet 18½" x 13½" x 9" deep. Price 75/- plus 5/- packing and postage

Collaro 4-speed Changer £8.19.6, plus 5/- pkg. & post  
B.S.R. 5-speed Changer £7.19.6, plus 5/- pkg. & post



Amplifier Cabinet £2.19.6,  
plus pkg. and post 5/-

## THE "TRANSIDYNE"

### Printed Circuit Transistor Pocket Superhet

A printed circuit pocket size Transistor Receiver, professional in appearance and of outstanding performance. Incorporates T.C.C. printed circuit, six transistors (push-pull) to cover medium and long waves, utilises 2 Ever-Ready, or equivalent, No. 8 batteries. Attractive cream and red plastic cabinet with engraved dial. Overall dimensions 7½" x 3½" x 1½". Total weight when assembled, including batteries, only 20 oz. Our price for all required components, including batteries, £11.19.6, plus 2/6 p. and p. Complete cabinet and dial assembly, printed circuit, battery holder, nuts and bolts and full assembly instructions, 25/-, plus 1/6 p. and p.

PLEASE ADDRESS ALL ENQUIRIES TO — 207 EDGWARE ROAD . LONDON . W2

## THE NORA AM/FM RADIOGRAM CHASSIS

Designed for the American market by a famous continental manufacturer

CASH PRICE **£16.19.6** Plus 7/6 packing and carriage

OR Deferred Terms:

H.P. Deposit £8.9.6 and 10 monthly payments of 19/-,  
Credit Deposit £2.2.6 and 8 monthly payments of £2.1.3.

This chassis is of the very latest design and has a much wider coverage on f.m. than standard receivers. It has 5 valves plus a full-wave metal rectifier, piano type push buttons for long, medium, f.m. and gram., separate tuning on f.m. and a.m. and incorporating a ferrite rod aerial for medium and long wavebands, also gram. pick-up switching. Output 5 watts, dial size 12½" x 2½". Overall size 12½" x 5½" x 7½"



Radio Component Specialists since 1946. Staffed by Engineers and Radio Amateur Constructors who enthusiastically try to give you a square deal and

# FULL VALUE FOR MONEY—

*Try Us!*

SPEEDY MAIL ORDER SERVICE

## BAND III TV CONVERTER 180 Mc/s-205 Mc/s

Suitable London, Birmingham, Northern, Scottish, Welsh and I.O.W. ITA transmissions  
**Mk. 2 Model.** Latest cascade circuit using ECC84 and EF80 valves giving improved sensitivity (12 dB) over standard circuits, built-in power supply a.c. 200-250V. Dimensions only 6 1/2" x 3", ht 4". Simple and easy to fit—only external plug-in connections. Wired aligned and tested ready for use. State channel required. Guaranteed. Bargain offer—good results or full refund. **ONLY £3.19.6** Carr. and pkg. 2/6

Band I/Band III changeover switch and B.B.C. aerial socket can now be fitted and wired to the above converter for 8/- extra

## RECORD PLAYER BARGAINS New Reduced Prices!

**SINGLE PLAYERS.** 4-speed BSR (TU9) 92/6; 4-speed GARRARD (4 S.P.), £7.15.0, carr. and ins. 3/6  
**AUTO-CHANGERS.** 4-sp. BSR (UA8), 6.19.6  
4-speed COLLARO, £7.19.6; 4-speed GARRARD (RC120/4H/2), £10.5.0, carr. and ins. 5/-. All above units are latest 4-speed models, fitted lightweight crystal p.u. and twin sapphire styli. Complete and ready to use.

**FINEST SELECTION AVAILABLE—ALL BRAND NEW AND GUARANTEED**

## 80 OHM CABLE COAX NOW ONLY 8d. YARD!

Highest Quality Cable, low-loss Polythene Aerialax, semi-air spaced, feeder losses cut 50%. Standard 1/2" dia. Stranded core.  
20 yds 12/6, carr. 1/6      40 yds 20/-, carr. 2/-  
Coax Plugs 1/-, Coax Sockets 1/-, Couplers 1/3,  
Outlet Boxes 4/6, B1-B3 Xover Unit 7/6

## C.R.T. HEATER ISOLATION TRANS.

New improved types—mains prim. 200/250V tapped. All isolation transformers now supplied with alternative no boost, plus 25%, and plus 50% boost taps at no extra cost, all in one transformer. 2V 2A type, 12/6; 6.3V 0.6A type, 12/6; 10.5V 0.3A type, 12/6; 13V 0.3A type, 12/6. P. and p. 1/6. Other voltages in course of production. Small size and tag terminated for easy fitting. p. and p. 1/6.

**CONDENSERS.** Mica or s. mica. All pref. values. 2pF to 680pF, 6d. each. Ceramic types, 2.2pF to 5,000pF, 9d. each. Tubulars, 450V, Hunts and T.C.C., 0.001, 0.005, 0.01 and 0.1, 350V, 9d.; 0.02, 0.05, 0.1, 500V Hunts, T.C.C., 1/-; 0.25 Hunts, 1/6; 0.5 Hunts, 1/9; 0.001 6kV T.C.C., 5/6; 0.001 20kV T.C.C., 9/6, etc.

**RESISTORS.** Pref. values 10 ohms 10 megohms, 20% tol., 1/2W, 3d.; 1/4W, 5d.; 1W, 6d.; 2W, 9d.; 10% h-stab., 1/2W, 5d.; 1/4W, 7d.; 5% tol., 1/2W, 9d.; 1% h-stab., 1/2W, 1/6  
**PRE-SET W/W POTS.** TV knurled slotted knob type. 25 ohms to 30,000 ohms, 3/-; 50,000 ohms, 4/-; 50,000 ohms to 2 Megohms (carbon), 3/-

**VOLUME CONTROLS.** Log or Lin. ratios, 10,000 ohms-2 Megohms. Long spindles. 1 year guarantee. Midget Ediswan type, 1 1/8" dia. No sw. 3/-, D.P. sw. 4/9

**S.T.C. RECTIFIERS.** E.H.T. types, K3/25 2kV, 5/-; K3/40 3.2kV, 6/9; K3/45 3.6kV, 7/3; K3/50 4kV, 7/9; K3/100 8kV, 13/6, etc. Mains types: RM1 125V 60mA, 4/9; RM2 125V 100mA, 5/6; RM3 125V 120mA, 7/6; RM4 250V 250mA, 16/-; RM4B type 250V 275mA, 17/6, etc.  
**LOUDSPEAKERS.** P.M. 3 ohm, 2 1/2" Rola, 17/6; 3 1/2" Goodmans, 18/6; 5" R. & A., 17/6; 6" Celes., 18/6; 7" x 4" Goodmans, 18/6; 8" Rola, 20/-; 10" R. & A., 25/-, etc.

**SPEAKER FRET.** Expanded bronze anodised metal: 8" x 8", 2/3; 12" x 8", 3/-; 12" x 12", 4/6; 12" x 16", 6/-; 24" x 12", 9/-, etc. **TYGAN FRET** (Murphy pattern): 12" x 12", 2/-; 12" x 18", 3/-; 12" x 24", 4/-, etc.

**L.F. CHOKES**—10H 65mA, 5/-; 15H 100mA, 10/6; 10H, 120mA, 10/6; 20H 150mA, 15/6

## ANOTHER T.R.S. WINNER

**LATEST 4-SPEED BSR** Player unit and pick-up, £4.12.6, carriage 3/6

**2-VALVE AMPLIFIER** wired complete with speaker, etc., on mounting board, £3.5.0, carr. 2/6

**CONTEMPORARY STYLED LIGHTWEIGHT CASE** in maroon and grey, size 14 1/2" x 11 1/2" x 6", £1.7.6, carriage 2/6

**SPECIAL OFFER—ALL 3 UNITS ONLY £9, CARRIAGE 4/6**

We can only show a small selection from our vast stocks in this advert. Write now for full Bargain Lists, 3d.

**OUTPUT TRANS.** Standard pentode, 4/6; push-pull 12V, 13/6. Small pentode, 3/9. Midget battery pentode (1S4, etc.), 4/6

**RE-GUNNED TV TUBES—GENUINE OFFER**  
New heater, cathode and gun assembly can now be fitted to your old tube, revacuumed and reconditioned virtually as new. Fully guaranteed to highest standards—as used by our own Service Department. 12" £8; 14" £8.10.0; 17" £10. We regret only Mullard and Mazda types at present. Delivery approximately 7 days. Carriage and insurance 12/6

**MIDGET TRANSISTOR TYPE ELECTROLYTICS.** T.C.C. 2µF, 4µF, 8µF 6V, 3/6; 6µF, 10µF, 16µF 3V, 3/6; 32µF 1 1/2V, 3/6, etc.

## VALVES—NOW BOXED—ALL GUARANTEED

1R5, 1T4, 7/6; 1S5, 1S4, 7/6; 3S4, 3V4, 8/-; 5Z4, 9/6; 6AT6, 8/6; 6K7, 6/6; 6K8, 8/6; 6Q7, 8/6; 6SN7, 8/6; 6V6, 7/6; 6X4, 7/6; 6X5, 7/6; 7C5, 9/-; 7Y4, 8/6; DAF96, 9/-; DF96, 9/-; DK96, 9/-; DL96, 9/-; 35L6, 10/6; EABC80, 9/6; EB91, 6/6; EBC41, 10/6; EBC33, 8/6; ECC84, 12/6; ECH42, 10/6; ECH81, 10/6; ECL80, 12/6; EF41, 10/6; EF80, 10/6; EF86, 13/6; EF91, 8/6; EY51, 12/6; EZ40, 8/6; EZ80, 8/6; MU14, 9/6; PCC84, 10/6; PCF80, 10/6; PCF82, 10/6; PCL83, 12/6; PL81, 14/6; PL82, 10/-; PL83, 11/6; PY80, 9/6; PY81, 9/6; PY82, 8/6; U25, 13/6; UY41, 8/6

**SPECIAL**—1R5, 1T4, 1S5, 1S4 or 3S4 or 3V4 per set 27/6

Hours 9 a.m.—6 p.m., 1 p.m. Wed.



# RADIO COMPONENT SPECIALISTS

70 Brigstock Road Thornton Heath Surrey

Telephone THO 2188

Terms: C.W.O. or C.O.D. Post and packing up to 1/2 lb 7d., 1 lb 1/1, 3 lb 1/6, 5 lb 2/-, 10 lb 2/9

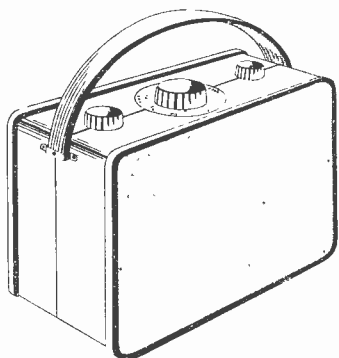

# REPANCO MAJOR-7

ALL TRANSISTOR PORTABLE

A design embodying 7 brand new transistors

- ★ New Transistors throughout—no surplus.
- ★ Output: 200 milliwatts.
- ★ Fully Tunable over Long and Medium Wave.
- ★ Super sensitive Ferrite Slab Aerial.
- ★ Eliptical Speaker 7" x 4".
- ★ Eyeletted chassis for easy wiring.
- ★ Automatic Volume Control.
- ★ Negative Feed Back.
- ★ 465 kc/s Intermediate Frequency.
- ★ Contemporary Cabinet in Cream and Black.
- ★ Cabinet Dimensions: 9" x 6½" x 4".
- ★ Easy to Build—point to point plans.
- ★ May be used as a combined Car Radio/Portable.

The MAJOR-7 may be built for

(Post Free) **£13 · 19 · 6**

Comprehensive wiring plans and instructions with detailed price list 1/9 (post free).

**RADIO EXPERIMENTAL PRODUCTS LTD**

33 MUCH PARK STREET COVENTRY



- ★
- 10-1,000 d.c. volts
- 10-1,000 a.c. volts
- 100 Microamps to
- 500 Milliamps d.c.
- 100 Microamps a.c.
- 0-1 Megohm
- 0-10,000 ohms

You, too, can be SELF-CONTAINED, or completely equipped to tackle any testing job, by owning one of the well-known M.I.P. Series 100 Multi-Range Test Sets. You can have one sent you almost immediately, simply by sending a deposit of 47/6. Balance is payable in 6 monthly instalments of £1.16. Cash price is £12.7.6. Post coupon for full details.

★  
There is also the **SERIES 90 MULTI-RANGE TEST SET** having 19 SELF-CONTAINED ranges:

ac/dc volts up to 1,000V  
dc current up to 500mA  
ac current up to 200µA  
Resistance 0-200,000Ω  
Deposit 35/- and six monthly payments of 28/10 (Cash price £9.15.0)



GD21

## MULTI-RANGE TEST SET - SERIES 100

To **MEASURING INSTRUMENTS (Pullin) Ltd.**  
Electrin Works, Winchester Street, Acton, W.3  
Please send illustrated leaflet of the Series 100 with details of easy payment scheme  
Ditto Series 90

\*Please indicate instrument required

NAME \_\_\_\_\_  
ADDRESS \_\_\_\_\_



F1158



# EMI

"HIS MASTER'S VOICE"  
MARCONIPHONE · COLUMBIA

Announce

## NEW PRACTICAL WAY OF LEARNING AT HOME

**NEW**— completely up-to-date methods of giving instruction in a wide range of technical subjects specially designed and arranged for self-study at home under the skilled guidance of our teaching staff.

**NEW**— experimental outfits and lesson manuals are despatched on enrolment and remain the student's property. A tutor is allotted to each student for personal and individual tuition throughout the course.

Radio and television courses, with which specially prepared components are supplied, teach the basic electronic circuits (amplifiers, oscillators, detectors, etc.) and lead, by easy stages, to the complete design and servicing of modern Radio and T/V equipments.

If you are studying for an examination, wanting a new hobby or interest, commencing a career in industry or running your own full-time or part-time business, these practical courses are ideal and may be yours for moderate cost. Send off the coupon to-day for a free Brochure giving full details. There is no obligation whatsoever.

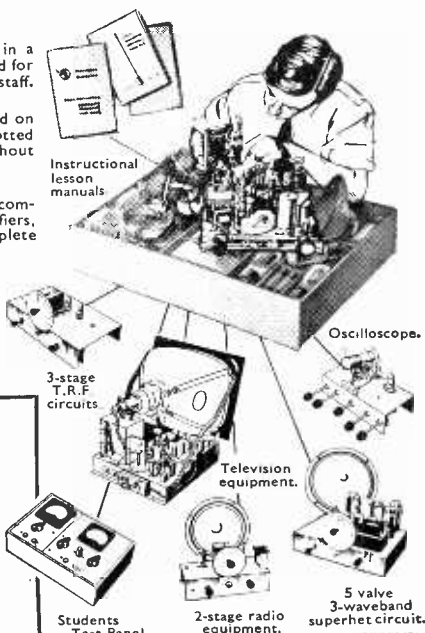

### Courses with Equipment

**RADIO · SHORT WAVE RADIO**  
**TELEVISION · MECHANICS**  
**CHEMISTRY · PHOTOGRAPHY**  
**ELECTRICITY · CARPENTRY**  
**ELECTRICAL WIRING · 'HI-FI'**  
**DRAUGHTSMANSHIP · ART, etc.**

E.M.I. Factories  
at Hayes,  
England.



# EMI INSTITUTES

Fill in for **FREE BROCHURE**  
E.M.I. INSTITUTES, Dept. 179X, London, W.4.

Name..... Age.....  
(If under 21)

Address.....

I am interested in the following subject(s) with/  
without equipment.....  
(We shall not worry you with personal visits)

**BLOCK  
CAPS  
PLEASE**

IC.107  
Nov/58



*The only Home Study College run by a World-wide industrial organisation*

---

# *There's nothing so good*

## AND IT'S BEST IF IT'S A

**Jasonkit**

When good circuitry and design are presented with straightforward, easily followed instructions, it becomes relatively simple to build technically advanced items of radio, audio and electronic equipment. There are already years of specialised experience in kit design and production behind the new Jasonkit programme. From it, the constructor can choose stereo amplifier and pre-amp designs, first-class f.m. tuners, and soon, a number of items of valuable electronic test equipment. Such is the quality of Jason designs that even to-day, the popularity of the original f.m. tuner, which was the first Jasonkit to be produced, is as great as ever and large numbers continue to be built with complete success.

No special tools or experience are required to build Jasonkits. To the satisfaction of building your own apparatus is added the knowledge that its performance will be the finest possible in its class. Kits are complete, too, down to the last detail, and include chassis and panels punched and drilled to size. Only valves are extra except where otherwise stated.

### **BRITISH THROUGHOUT**

*Details of kits in which you are interested gladly sent on request*

**(SEE US AT STAND 18 RADIO HOBBIES EXHIBITION)**

# **THE JASON MOTOR & ELECTRONIC SALES CO**

# as building it yourself

FM tuners  
am/fm tuners  
fm/tv tuners  
stereo amplifiers  
stereo pre-amplifiers  
electronic instruments



## AUDIO

	STANDARD FM TUNER in chassis form (less valves)	£5.5.0
	Power Pack Kit	£2.1.9
ARGONAUT AM/FM TUNER.	As tuning unit only (less valves) ... ..	£10.10.0
	As complete receiver (less valves) ... ..	£11.10.0
MERCURY SWITCHED FM TUNER	including front end with 2 valves	£9.0.0
STEREO AMPLIFIER (10+10 watts)	Power Amplifier with 7 valves ... ..	£17.8.0
STEREO PRE-AMP J.4-4	with case, but less valves ... ..	£16.10.0
STEREO PRE-AMP J.3-3	with valves and case ... ..	£16.15.0
STEREO PRE-AMP J.3-3	with valves, less case ... ..	£16.0.0
SIMPLIFIED STEREO AMP	with tone, balance and channel controls (3+3 watts) with valves and case ... ..	£13.19.0
FRINGE FM TUNER,	self-powered, less valves ... ..	£8.5.0
SWITCHED FM/TV SOUND TUNER,	self-powered, less valves ... ..	£12.19.0

## INSTRUMENTS

VALVE VOLTMETER : WOBBULATOR : STABILISED POWER PACK :  
OSCILLOSCOPE.—For all who wish to build and experiment to a high degree of accuracy.  
These kits have attractive uniformly styled front panels and may be built with or without  
the standardised cases. FOR RELEASE SHORTLY.

3-4(E) GT. CHAPEL STREET OXFORD STREET LONDON W1

(between Tottenham Court Road and Oxford Circus Station Underground)

Telephone GERard 0273/4

# CLYNE RADIO LTD



**"The Component Specialists"**

ALL POST ORDERS AND CORRESPONDENCE TO  
162 HOLLOWAY ROAD · LONDON N7  
NOR 6295/6/7

18 TOTTENHAM COURT RD. LONDON W1  
MUS 5929/0095

Callers welcome at both branches

## MULLARD TYPE "C" TAPE PRE-AMPLIFIER

(as described in this issue)

All necessary components, including valves, for this truly "Hi-Fi" pre-amplifier can be supplied at a special inclusive price of

**ONLY  
10 GNS.**  
plus 3/6 P. & P.

All components available separately if required: Send stamp for price list.

**POWER PACK.** All necessary components for power pack for above amplifier.

**37/6**  
inclusive  
plus 1/6 P. & P.

## "R.E.P. MINI-7"

POCKET TRANSISTOR PORTABLE

- ★ Utilises 7 specially selected transistors.
- ★ Push-pull output.
- ★ Hi-Grade 2½" p.m. loudspeaker.
- ★ Ferrite slab aerial.
- ★ Most attractive appearance.
- ★ Exceptionally good quality output.
- ★ Unequaled performance.

Overall dimensions only 5¼" x 3¾" x 1¼". Powered by two miniature 3V transistor batteries. Plastic case finished in dove grey with scarlet knobs.

ALL NECESSARY COMPONENTS  
AT SPECIAL INCLUSIVE PRICE OF

**£9.19.6**  
P. & P. 2/6

## PRINTED CIRCUIT "THE TRANSIDYNE"

SIX TRANSISTOR POCKET SUPERHET

Incorporates push-pull output, covers medium and long waves. Attractive cream/red plastic cabinet and dial. Size 6¼" x 3¾" x 1½". All required components, including batteries £11.19.6, plus 2/6 P. & P. Full instructions parts list 1/- post free. All components can be supplied separately, for example: Complete cabinet, dial assembly, printed circuit, battery holder, nuts, bolts and full instructions 25/- plus 1/6 P. & P. 3 required Audio Transistors, 22/6 per set. 3 required R.F. Transistors, 45/- per set.

## MULLARD 510 PRINTED CIRCUIT HI-FI AMPLIFIER

This very famous amplifier is ideal and recommended for use in conjunction with the above Tape Pre-Amp., enabling unequalled Hi-Fidelity recording and playback from any tape deck! All required components available at **£9.9.0** (including Ultra-only Linear output stage) plus 3/6 P. & P.

or assembled and tested £12.12.0.

THIS COMBINATION WILL BE THE ENVY OF ANYONE INTERESTED IN QUALITY RECORDING AND REPRODUCTION!!!

Itemised price list and comprehensive instruction book 3/6, post free.

## CONSTRUCTORS BARGAINS!

**RF26 Unit.** 50-60 mc/s. Brand new, 22/6. P and p. 2/-.

**Mains Transformer (Special).** Superior quality drop through type, half shrouded. Primary 200/250V Secondary 350-0-350V at 80mA, 6.3V 3A, 5V 2A. Ex-equipment, but guaranteed O.K. Only 9/6 plus 1/- p. & p.

**6V Vibrator Pack.** Ex-V.D. Output 140V 30mA. Fully smoothed. Size only 6¼" x 5" x 2¼". New condition. 12/6 plus 1/6 p. and p.

**12V Vibrator Pack.** Mallory, brand new. Output 150V 40mA. Complete with synchronous vibrator. 12/6 plus 1/6 p. and p.

**12" Plessey P.M. Loudspeaker.** 3 ohm speech coil. Brand new. Only 32/6 plus 2/6 p. and p.

**12" Bakers Selhurst Loudspeakers.** 15 ohm, 15 watt, 30/14,000 c/s. Few only. Brand new. £4 10s. plus 3/6 p. and p.

**10" Recond. good quality Loudspeaker.** Complete with o.p. transformer, as good as new. 17/6 plus 1/6 p. and p.

**Wiring Wire.** 5 coils 10yd each coil, in different colours, contained in cellophane bag. 5/- plus 9d. p. and p.

**3-Section Whip Aerials.** Ideal for fishing rods, etc. Each section 4ft. Only 7/6 set, plus 2/6 p. and p.

**H.G.P.59 Crystal Insert.** Complete with l.p. and std. sapphire styli. Brand new, 18/- plus 9d. p. and p. Suitable for B.S.R., Monarch, etc.

**Manufacturers' Surplus Component Strips.** Comprising approx. 12 capacitors from 0.25µF to 100pF and approx. 12 resistors. All useful values. Mounted on sturdy tag board. 4 Strips (approx. 100 components) for 5/- plus 1/- p. and p.

**Nylon Drive Cord.** 12yd reels. Best quality 3/6 plus 6d. p. and p.

**CLR Low Impedance Headphones** 7/6 pair plus 1/- p. and p.

**Brand new imported High Impedance Lightweight Headphones.** Finished in cream. 15/- pr. plus 1/- p. and p.

**Carbon Hand Microphones** complete with press to talk switch. Lead and jack plug. 5/- each, plus 1/- p. and p.

**Morse Keys.** Superior Quality. Brand new 2/6 plus 1/- p. and p.

**Octal Plugs.** Ex-equip. 9d. each, plus p. and p. 6d.

**Packard Bell Pre-Amplifier. Snip!** With 6SL7GT, 28D7GT, plugs, hand switch, many components contained in useful metal case. Brand new, boxed complete with circuit diagram and instruction book. Only 12/6 plus 1/6 p. and p.

**Polystyrene Coil Cement.** 1/10 per bottle plus 6d. p. and p.

**We Specialise in VALVES . COMPONENTS . AM & FM CHASSIS TUNERS . AMPLIFIERS . LOUDSPEAKERS . CABINETS . RECORD PLAYERS . TAPE RECORDERS and all HI-FI EQUIPMENT Enquiries invited**

# Wanted!

**QUALIFIED MEN AND WOMEN**

Industry and Commerce offer their best posts to those with the qualifications — appointments that will bring personal satisfaction, good money, status and security. As part of a modern industrial organisation, we have skilled knowledge of what is required and the best means of training personnel for its present day and future requirements. We specialise also in teaching for hobbies, new interests or part-time occupations in any of the subjects listed below. Write to us to-day for further information. There is no obligation of any kind.

### PERSONAL & INDIVIDUAL TRAINING IN —

- |                                       |                                  |                                  |
|---------------------------------------|----------------------------------|----------------------------------|
| Accountancy                           | Electronics                      | Production                       |
| Advertising                           | Electronic                       | Planning                         |
| Aeronautical Eng.                     | Draughtsmanship                  | Radar                            |
| A.R.B. Licences                       | Eng. Drawing                     | Radio                            |
| Art (Fashion, Illustrating, Humorous) | Export                           | Radio Amateur's (C&G) Licence    |
| Automobile Eng.                       | General Certificate of Education | Radio & Television Servicing     |
| Banking                               | Heating & Ventilating Eng.       | Refrigeration                    |
| Book-keeping                          | High Speed                       | Sales Management                 |
| Building                              | Oil Engines                      | Sanitary Eng.                    |
| Business Management                   | Industrial Admin.                | Salesmanship                     |
| Carpentry                             | Jig & Tool Design                | Secretaryship                    |
| Chemistry                             | Journalism                       | Shorthand & Typing               |
| City & Guilds                         | Languages                        | Short Story Writing              |
| Exams                                 | Management                       | Short Wave Radio                 |
| Civil Service                         | Maintenance Eng.                 | Sound Recording & Reproduction   |
| Commercial                            | Mathematics                      | Telecommunications               |
| Subjects                              | M.C.A. Licences                  | Television                       |
| Commercial                            | Mechanical Eng.                  | Time & Motion Study              |
| Art & Drawing                         | Metallurgy                       | Tracing                          |
| Customs Officer                       | Motor Eng.                       | Welding                          |
| Draughtsmanship                       | Painting & Decorating            | Workshop Practice                |
| Economics                             | Photography                      | Works Management and many others |
| Electrical Eng.                       | P.M.G. Cert.                     |                                  |
| Electrical Installations              | Police                           |                                  |
|                                       | Production Eng.                  |                                  |

### OUR BACKGROUND!

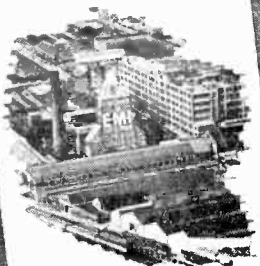

The E.M.I. Factories at Hayes, England.

Also courses for GENERAL CERTIFICATE OF EDUCATION, A.M.I.H.&V.E., A.M.S.E., A.M.Brit.I.R.E., A.M.I.Mech.E., A.M.I.E.D., A.M.I.M.I., A.F.R.Ae.S., A.M.I.P.E., A.M.I.I.A., A.C.C.A., A.C.I.S., A.C.C.S., A.C.W.A., City & Guilds Examinations, R.T.E.B.Serv. Cert. R.S.A. Certificates, etc.

The only Home Study College  
operated by a world-wide  
manufacturing organisation

**NEW!** Courses with **PRACTICAL EQUIPMENT**  
IN RADIO · TELEVISION · MECHANICS · CHEMISTRY  
ELECTRICITY · DRAUGHTSMANSHIP  
PHOTOGRAPHY, ETC., ETC.

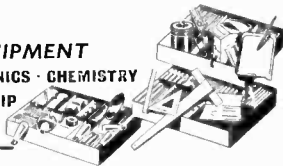

# EMI

## INSTITUTES

### POST THIS TODAY

E.M.I. INSTITUTES, Dept. 179K, London, W.4

NAME \_\_\_\_\_ AGE (if under 21) \_\_\_\_\_

ADDRESS \_\_\_\_\_  
I am interested in the following subject(s) with/without equipment \_\_\_\_\_

Nov/58

(We shall not worry you with personal visits).



BLOCK  
CAPS  
PLEASE

IC 92

*The only Home Study College run by a World-wide industrial organisation.*

### MULLARD TAPE AMPLIFIERS

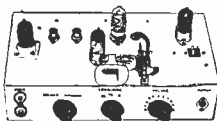

All parts in stock for the Mullard type A and C tape amplifiers including ready wound ferroxcubes. Send 3d. stamp for detailed price lists.

### JASON STEREO

All component parts in stock. 3d. stamp for price list. Start this new exciting super Hi-Fi today and amaze your friends. RONETTE stereo and L.P. cartridge £3.9.6. Stereo, L.P. and 78. turn-over cartridge £4.3.5.



WE STOCK THE FULL RANGE OF "BERON" CHASSIS AS ADVERTISED IN THIS ISSUE.

### HEADPHONES



Brand new light-weight high resistance headphones. Resistance 4,000 ohms. Made to highest standard by B.T.H. Individually boxed. NOT ex-govt. List price 45/- **OUR PRICE 15/-**, post 1/-

### MINIATURE 2-GANG

Brand new 500pF miniature two gang. 2" x 1 1/2" x 1 1/8". Ideal for small radio or portable.



**OUR PRICE 3/6**  
post 9d.

### 6 1/2" WAFER SPEAKERS

Brand new wafer type speakers. Front to back only 1 1/2". Ideal for tape recorders, portables, etc. 3 ohms. **OUR PRICE 15/-**, post 1/-.



### "EMPRESS" SA4 STEREPHONIC AMPLIFIER



Full stereo amplifier. 3 1/2 watts each channel. 3 ohms output. Tone, Balance and volume control. Complete and ready to use. Amazing value. Call for demonstration. **PRICE £8.0.0.** post 2/6.

### TRANSIDYNE AND MINISEVEN

All parts in stock for these transistor pocket portables. 3d. stamp for detailed price lists.

Meet us at Stand 20

**RADIO HOBBIES EXHIBITION**

in London 26th-29th November.

# HOME RADIO

(MITCHAM) LTD. Dept. C

187 LONDON ROAD MITCHAM SURREY

Shop hours 9-6.30 p.m., Weds. 9-1 p.m. MIT 3282

### JACK PLUGS AND SOCKETS

(by Bulgin)

Miniature type 3/8" diameter, panel space. 3/8" behind panel. With optional closed circuit leaf.

Plug 3/- Socket 2/6

Sub-miniature type 3/8" x 1/2" panel space. 1/2" behind panel, 3/8" projection.

Plug 9d. Socket 1/3

### The TRANSIDYNE RECEIVER

(Page 119 Sept. issue)

We guarantee all components to be exactly as specified by designer & approved by Messrs. Teletron Drilled case, printed circuit, battery holder, dial, nuts, screws £15.0  
Complete coil and aerial kit £2.2.0  
Resistor kit (with circuit refs.) 6/-  
Cond. kit (with circuit refs.) £15.0  
Rola speaker (tax paid) £1.8.2  
J.B. tuning condenser with centre screen 10/6  
Ardenite D131 & D132 per pr. £15.6  
Ardenite volume control (R15) 12/6  
Slider wavechange switch 3/6  
GEX34 diode 4/-

COMPLETE KIT AS ABOVE AT THE SPECIAL PRICE OF £8.15.6  
Red/Yellow (r.f.) 15/- each  
Green/Yellow (audio) 9/6 each

COMPLETE KIT WITH TRANSISTORS AT THE SPECIAL REDUCED PRICE OF £11.19.6  
FREE—Special 'printed circuit' solder with each kit

Full constructional details, 9d.  
S.A.E. Price List

TRANSISTOR KITS. Companion £5.15.6. Leaflet 6d. 'Mini-7', £12.10.0. Envelope 1/6. Radiosette £2.3.0 (with phones)  
Price lists—S.A.E.

We recommend the 'LITESOLD' soldering iron for all fine work and printed circuits. Mains or battery. 2/6 complete (state mains voltage)

TRANSISTOR ITEMS. Electrolytics 8µF 6V, 16µF 12.5V, 32µF 3V, 5µF 12.5V, 5µF 40V, 2.5µF 40V, 1.6µF 6V, 25µF 6V. All 3/3 each; 100µF 6V 3/-; Paper 0.01, 0.001, 0.002, 0.005µF, all 8d. each. Transistor Holders 1/- each, 6 for 5/9, 11/- doz. Ardenite T.1065 transformers (page 911—July), 12/-.

Subminiature Speakers 1 1/2" round, 27/-; 2" x 3" elliptical, 33/-.

Output Transformers, single-ended or p/p, 12/6. Volume Controls, button type (totally enclosed), 47k and 1MΩ, 2/6; preset skeleton type 5k 2/6; spindle type, 1/2M, 1M, 2M, 4/3 (page 705—'R.C.' May).

Ardenite Catalogue 6d.

### MULTI-PURPOSE NEON TESTER

(Page 135 Sept. issue)

Complete kit. Containing resistors, condensers, special sub-miniature neon, fully insulated safety colour coded crocodile clips; sub-miniature jack and socket for output. Price complete 9/8 (Or with standard coax output 10/-)

### TRANSISTORS—CHEAPER STILL

Yellow/Red R.F. 15/-  
White Spot R.F. 14/-  
Yellow/Green A.F. 9/6  
Red Spot A.F. 9/-

QUOTATIONS gladly given (S.A.E. please)

## R. FAGELSTON (MAIL ORDER)

Please add Postage to above prices

• ~~~~~ 46 HARDWICKE ROAD · LONDON N13 ~~~~~ •

The

# Radio Constructor

incorporating THE RADIO AMATEUR



Vol. 12 No. 4

NOVEMBER 1958

ANNUAL SUBSCRIPTION 25/- (including postage)

## CONTENTS

*Editor*  
C. W. C. OVERLAND, G2ATV

*Associate Editor*  
A. C. GEE, G2UK

*Business Manager*  
J. H. BURROWS, A C A

*Advertising Manager*  
F. A. BALDWIN, A M I P R E

*Offices*  
57 MAIDA VALE LONDON W9

*Telephone*  
CUNNINGHAM 6141  
(2 lines)

*Telegrams*  
DATABUX, LONDON

**254** Suggested Circuits: Remotely Switched Television Pre-Amplifiers, *by G. A. French*

**259** In Your Workshop

**266** Understanding Television, Part 11  
*by W. G. Morley*

**273** Can Anyone Help?

**274** Radio Miscellany

**277** F.M. Facilitated, *by A. S. Carpenter*

**280** The Mullard Tape Amplifier Type "C," Part 1  
*described by R. Webb*

**286** The Cooper-Smith "Prodigy" 6-Watt High Fidelity Amplifier, Part 2, *described by J. Cooper*

**294** Models for Radio Control—The "Wavemaster," Part 4, *by Raymond F. Stock*

**296** Radio Hobbies Exhibition—List of Exhibitors

**297** Visit to the Siemens Edison Swan Sunderland T.V. Tube Factory

**298** A Sensitive Transistor Receiver, *by J. C. Baker*

**301** A Versatile Audio Frequency Oscillator  
*by D. E. Vaughan*

**302** A Power Unit—with a Difference, *by R. S. Squires*

## NOTICES

THE CONTENTS of this magazine are strictly copyright and may not be reproduced without obtaining prior permission from the Editor.

ARTICLES appearing in this magazine which describe kits are inserted only on condition that such kits, or special components thereof, are freely available at a trade discount to all retail advertisers.

OPINIONS expressed by contributors are not necessarily those of the Editor or proprietors.

THE EDITOR invites original contributions on construction of radio subjects. All material used will be paid for. Articles should preferably be typewritten, and photographs should be clear and sharp. Diagrams need not be large or perfectly drawn, as our draughtsmen will redraw in most cases, but all relevant information should be included.

ALL MSS must be accompanied by a stamped addressed envelope for reply or return. Each item must bear the sender's name and address.

TRADE NEWS. Manufacturers, publishers, etc., are invited to submit samples or information of new products for review in this section.

QUERIES. We regret that we are unable to answer queries, other than those arising from articles appearing in this magazine; nor can we advise on modifications to the equipment described in these articles.

ALL CORRESPONDENCE should be addressed to THE RADIO CONSTRUCTOR 57 Maida Vale London W9  
REMITTANCES should be made payable to "DATA PUBLICATIONS LTD."

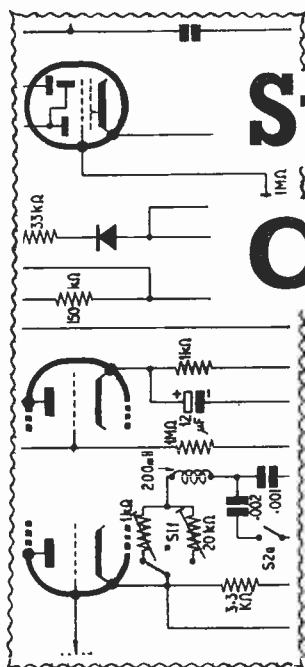

# Suggested Circuits

The circuits presented in this series have been designed by G. A. FRENCH, specially for the enthusiast who needs only the circuit and essential relevant data

## No. 96 Remotely Switched Television Pre-Amplifiers

READERS MAY RECALL THAT, IN *Suggested Circuits* No. 92 and 93,<sup>1</sup> the writer described two remote control systems wherein a large number of operations could be controlled from a remote point with the use of very few interconnecting leads. The circuits employed relays, and the writer made the comment at that time that relay circuits normally reflect considerable reader interest. This comment seems to have been borne out by the correspondence received since the two circuits were published. In this instance, however, readers seem to have been more interested in finding solutions to individual relay problems than they were in the more general theoretical principles involved in the articles themselves.

The writer was intrigued to note that one particular remote control problem was raised by several correspondents, this concerning the operation of television pre-amplifiers fitted close to the aerials with which they were used. Readers raising this matter wished to obviate running long mains leads from receivers to pre-amplifiers, or the necessity of climbing

several flights of stairs so that pre-amplifiers could be switched on and off. The writer is a little hesitant at introducing relay circuits so shortly after previous relay articles have appeared, but he feels that the interest exhibited in this particular problem provides a reasonable excuse. In any event, relays are employed in only two of the remote control circuits described here. The third circuit functions on an entirely different principle.

### Pre-Amplifier Control

The function of a television pre-amplifier is to amplify, at r.f., the signal picked up by the aerial and to present it to the associated receiver at an enhanced level. Because of this, television pre-amplifiers are normally employed in fringe areas. Provided that they have a low input noise level, television pre-amplifiers also serve the second important purpose of reducing picture noise level if the performance of the associated receiver's front-end circuits is poor in this respect.

To give optimum results, a television pre-amplifier should be mounted as close to the aerial as possible. It then handles a signal which has suffered minimum attenuation in

<sup>1</sup> Published in the July and August, 1958, issues.



the aerial feeder and it passes an amplified signal to the comparatively long feeder which couples it to the receiver. Under these conditions the incoming signal is more readily capable of over-riding the input noise level given by the pre-amplifier. Also, any interference picked up by the feeder coupling the pre-amplifier to the receiver is reproduced at a lower level than would otherwise have been the case.

In this article several methods of switching the television pre-amplifier on and off are dealt with. In all instances, the only inter-connecting link between the pre-amplifier and the receiver is the feeder line itself. In the last method discussed, this feeder carries the power for the pre-amplifier.

### Relay Circuits

Fig. 1 illustrates a simple remote control circuit. A relay is employed at the pre-

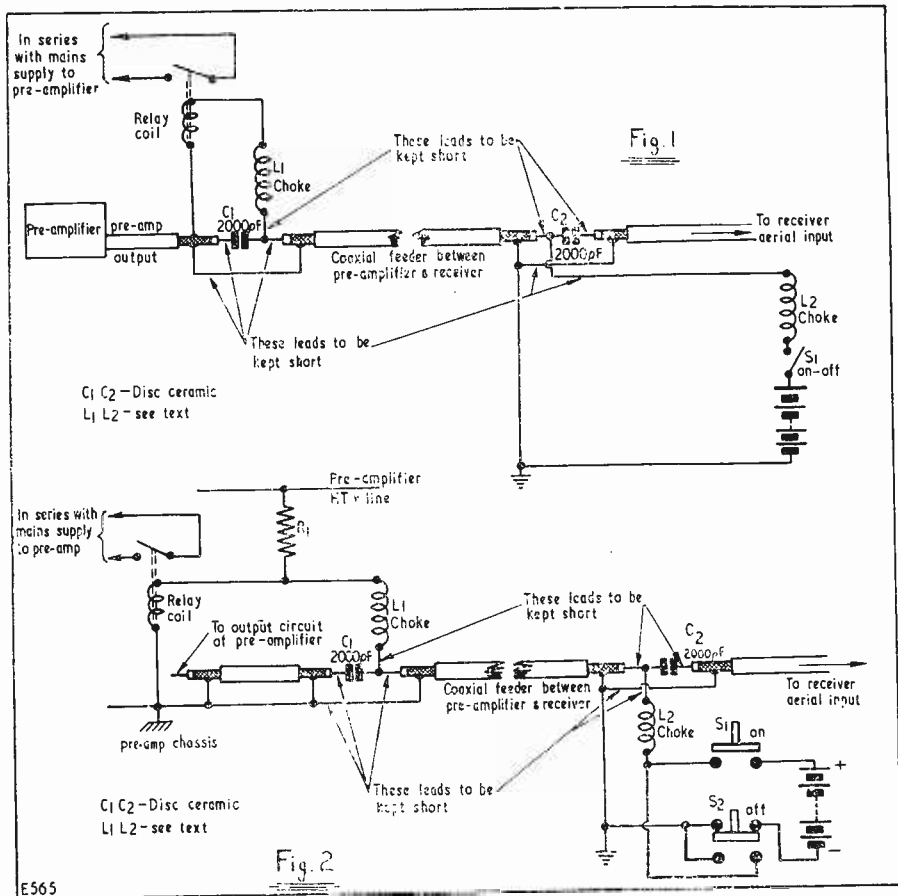

In practical television installations it is normally fairly easy to mount a pre-amplifier close to its aerial. Usually, this requires the pre-amplifier being fitted at a high point in the house, such places as attics, etc., providing adequate installation facilities. The problem then arises of providing a mains supply for the pre-amplifier and of switching it on and off. It is desirable, as we have just seen, to be able to switch the pre-amplifier from a point near the receiver.

amplifier and this is energised via the inter-connecting co-axial cable. It is assumed that a source of mains voltage is available close to the pre-amplifier.

In Fig. 1 the output of the pre-amplifier is applied to the co-axial feeder via the 2,000pF condenser  $C_1$ . The impedance of  $C_1$  is low at television signal frequencies, and negligible loss of signal level should result due to its insertion. A similar condenser,  $C_2$ , is inserted between the co-axial feeder and the

receiver input socket. In consequence, it becomes possible to pass a d.c. control voltage along the interconnecting co-axial cable. In the diagram a suitable control voltage is provided by a battery at the receiver, this being connected across the co-axial feeder by means of switch  $S_1$ . When switch  $S_1$  is closed, the battery energises the relay at the pre-amplifier, thereby switching the latter on.

The circuit between the battery and the relay is completed via the two series chokes  $L_1$  and  $L_2$ . These chokes should each have an inductance lying between 1.5 and 2.5 $\mu$ H, and they should cause no noticeable attenuation in signal level. Suitable commercially-available components are discussed at the end of this article.

The circuit of Fig. 1 has the advantage of considerable simplicity, but it suffers from the fact that the battery discharges continually during the time that the relay is energised. A more economic version would employ, at the receiver, a small mains power unit having a low-voltage d.c. output. Despite its simplicity, Fig. 1 is still of value, nevertheless, and it helps to demonstrate the arrangements needed for passing control voltages along a co-axial cable which is already carrying a signal voltage.

A more complicated relay circuit is shown in Fig. 2. This arrangement is basically similar to that employed in an earlier Suggested Circuit,<sup>2</sup> a number of component values being altered to fit it for its present purpose.

The relay in Fig. 2 is a component having a coil resistance around 2,000 ohms or more, and should be capable of remaining energised by a "holding-on" current of several milliamps. The battery at the receiver has a voltage which is capable of initially energising the relay. Normally, one or two 9-volt grid bias batteries at the receiver should provide an adequate energising potential. The life of these batteries should be only slightly shorter than their shelf life, as they are required to energise the relay for brief periods only.

When the "On" button of Fig. 2 is depressed, the battery is connected, via the interconnecting co-axial feeder and chokes  $L_1$  and  $L_2$ , to the relay coil. The relay energises, switching on the mains supply to the pre-amplifier. As soon as an h.t. voltage becomes available at the pre-amplifier a current flows through resistor  $R_1$  to the relay coil and battery in parallel. The "On" button may then be released, whereupon the current from the pre-amplifier h.t. supply will maintain the relay in the energised position.

When it is desired to switch off the pre-

amplifier the "Off" button is depressed. This causes chokes  $L_1$  and  $L_2$ , in series, to be connected across the relay coil, effectively shortcircuiting it. The relay, in consequence, de-energises, and breaks the mains supply to the pre-amplifier. When the "Off" button is released the relay remains in the de-energised position as there is now no energising voltage available from the pre-amplifier h.t. line.

The period of time during which the "On" button of Fig. 2 has to be depressed depends upon the type of h.t. rectifier employed at the pre-amplifier. If, as is most probable, a metal rectifier is employed, h.t. will appear almost immediately, whereupon the button need only be depressed for a second or so. If a valve rectifier is used it will be necessary to keep the button depressed for a longer time. With directly heated rectifiers the button would need to be depressed for some five to ten seconds, which is not, perhaps, too excessive. Indirectly heated rectifiers would incur a longer delay and it would be preferable to replace such rectifiers with directly heated, or metal, types.

In the interests of h.t. current economy, the resistor  $R_1$  should have a value which just comfortably enables the relay to remain in the energised position. The current needed for this condition will be lower than that needed to initially cause the relay to operate, this latter being provided by the battery. It should be noted that the battery should be connected into circuit with correct polarity, so that the energising current it provides flows through the relay coil in the same direction as does that from the h.t. supply. The circuit is economic in operation because the battery provides current only during the time that the "On" button is depressed. It will be seen that the "Off" button has a pair of contacts which are made when it is in the released position. The purpose of these contacts is to ensure that the battery is not short-circuited if both buttons are accidentally depressed at the same time. The circuitry around the "Off" button is arranged such that a simple s.p.d.t. arrangement is required here.

The point has to be made that the circuit of Fig. 2 cannot be used if the additional current drawn by the relay coil overloads the pre-amplifier h.t. supply. Normally this should not occur, but it is advisable to check before using the circuit. Fig. 2 assumes also that the pre-amplifier chassis is isolated from the mains supply. The circuit must *not* be used if the pre-amplifier chassis (or its h.t. negative line) is connected to one side of the mains.

In both Fig. 1 and Fig. 2, care has to be taken to ensure that the blocking condensers  $C_1$  and  $C_2$  are reliable ceramic components and that they are connected into circuit via

<sup>2</sup> Suggested Circuits No. 76—A Simple Remote Control Device Employing Existing Speaker Leads; *The Radio Constructor*, March 1957.

very short leads. Chokes  $L_1$  and  $L_2$  should be positioned very close to the co-axial centre conductors to which they connect. Many television receivers will have input circuits consisting of isolating condensers which are bridged by high value resistors. If this is the case  $C_2$  is not required, the co-axial centre conductors connecting together directly at this point. A final fact is that care has to be taken with the relays employed for switching the mains supply at the pre-amplifier. It is most important to ensure that the insulation between the contacts and coil of whatever relay is employed is adequate to withstand mains potentials, in order to prevent shock or accident.<sup>3</sup> It is also advisable to earth the outer braiding of the co-axial cable to a reliable electrical earth, as shown in the diagram.

feeder itself. It must be emphasised that the circuit of Fig. 3 may be a little more difficult to get into working order than are those of Figs. 1 and 2, as it is necessary for a certain amount of experimental work to be carried out. Also, the mains transformer needed at the receiver may not be directly available, it being necessary to employ modified connections to a standard component. Further, alterations to the pre-amplifier power supply circuits are needed. The writer would recommend that this circuit arrangement be tackled by the more experienced constructor only.

The circuit of Fig. 3 functions under the principle that power at a low voltage is fed along the co-axial feeder between the pre-amplifier and the receiver, this being applied directly to the heater of the pre-amplifier

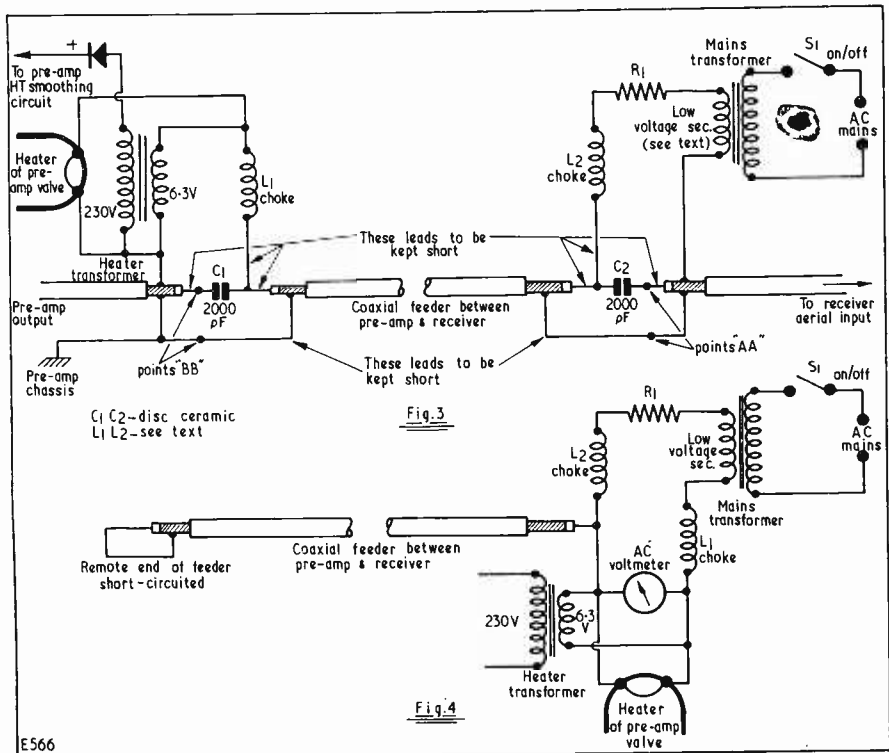

### Remote Power Circuit

Fig. 3 shows an entirely different approach to the problem. In this circuit there is no relay and there is no necessity to have a mains point near the pre-amplifier because the power for this is passed along the co-axial

valve and to a step-up transformer which provides a suitable high voltage for h.t. rectification. It is assumed in the diagram that the pre-amplifier valve has a 6.3 volt heater, whereupon a conventional heater transformer can be connected "back-to-front" in order to provide h.t. A metal h.t. rectifier at the pre-amplifier is almost essen-

<sup>3</sup> This assumes that the metalwork of the relay is isolated from chassis.

tial, as a valve rectifier would consume an undesirably high heater current with consequently increased volts drop in the interconnecting feeder. As may be seen, the use of the Fig. 3 circuit incurs modification to whatever power supply circuits are already fitted to the pre-amplifier. Care should be taken to ensure that the h.t. voltage provided by the "back-to-front" heater transformer is similar to that given previously. At the receiver end of the co-axial feeder, all that is required are the isolating components  $C_2$  and  $L_2$ , a mains transformer, a series resistor  $R_1$ , and an on-off switch.

The presence of the series resistor  $R_1$  is due to the fact that a marked volts drop will occur in chokes  $L_1$  and  $L_2$ , and in the co-axial feeder coupling the receiver to the pre-amplifier. It thereupon becomes necessary to use a mains transformer at the receiver end whose secondary voltage is equal to, or greater than, that required to overcome this volts drop; the series resistor being adjusted to the value which ensures that the correct voltage appears at the pre-amplifier end of the cable. In order to reduce the a.c. voltage appearing across the feeder the series resistor is fitted at the receiver end, even though this complicates the procedure of initially finding the value it requires.

To determine the requisite value for  $R_1$ , and the required secondary voltage of the mains transformer at the receiver end, it is first of all necessary to roughly determine the current requirements of the pre-amplifier, together with the resistance inserted by the chokes and the feeder. To take an example, a pre-amplifier employing a single ECC84 would require a heater current of 0.34A, plus a primary current, for the "back-to-front" heater transformer at the pre-amplifier, of some three-quarters of an amp; these totalling approximately 1.1 amps. The resistance of the co-axial feeder should next be measured, this being carried out by short-circuiting it at one end and measuring the resistance across the other end. With normal feeder a resistance of some 5 ohms per 100 feet is the sort of thing to expect. In the case we have just considered, the 1.1 amp current required by the pre-amplifier would result in a drop of some 5.5 volts for every 100 feet of interconnecting feeder. These initial resistance measurements assist in determining what secondary voltage approximately is required of the mains transformer at the receiver end.

After the pre-amplifier power circuits have been modified to those shown in Fig. 3 it may be connected up temporarily in the manner illustrated in Fig. 4, the resistance of the interconnecting feeder being inserted in series with the input to the pre-amplifier by short-

circuiting it at the remote end. The series resistor,  $R_1$ , is now adjusted in value until 6.3 volts a.c. is indicated by the voltmeter connected across the pre-amplifier valve heater and step-up transformer primary.

We have mentioned the fact that the secondary voltage required of the mains transformer at the receiver end is almost certain to be of a non-standard nature, and it may be necessary to use such devices as connecting in series the 6.3 and 5 volt windings of a conventional mains transformer to provide the voltage required. The secondary of the mains transformer should be capable of supplying the current needed by the pre-amplifier. In some instances it may be found that the secondary provides a voltage sufficiently close to what is required for  $R_1$  to be dispensed with.

After the correct value for  $R_1$  has been determined by the set-up of Fig. 4 the pre-amplifier may be connected up permanently as illustrated in Fig. 3, whereupon no further adjustments should be required. There is, however, a slight risk of cross-modulation between the mains voltage appearing across the co-axial feeder and the input signal. If this should occur it may be cleared by connecting a 470 ohm resistor across the points marked AA in Fig. 3. In very severe cases it may be necessary to fit a further 1.5 to 2.5 $\mu$ H choke across these two points instead of the resistor. On the other hand, if there is no evidence of cross-modulation, and if the receiver employs an input isolation circuit consisting of condensers bridged by high value resistors, condenser  $C_2$  may be deleted, as occurred with Fig. 1 and 2. The possibility of cross-modulation occurring in the pre-amplifier is very remote, as the output circuit of this unit will consist almost always of a coupling coil having a low impedance to 50 c/s a.c. In the event that an alternative output circuit is employed any possible cross-modulation can be cleared by connecting a 470 ohm resistor (or, in severe cases, a 1.5 to 2.5 $\mu$ H choke) across the points marked BB in Fig. 3.

The requirements for short connecting leads in the co-axial circuits is of equal importance in Fig. 3 as it was in the circuits of Figs. 1 and 2.

### Isolating Chokes

After part from the mains transformer at the receiver end, the components required in the circuits described this month are easily obtainable. So far as isolating chokes are concerned, a suitable component would be the Teletron coil type 22. This coil has an inductance of approximately 2 $\mu$ H, and is capable of passing a continuous current of 3 amps.

# IN YOUR WORKSHOP

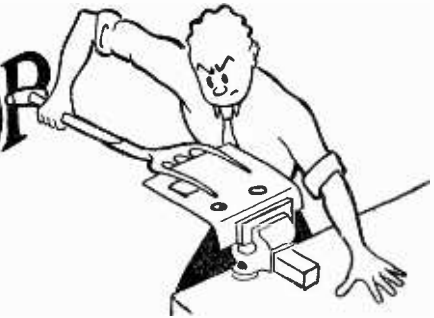

*This month Serviceman Smithy's able assistant, Dick, finds that things in the Workshop are not quite what he expected*

THE GREENWICH TIME SIGNAL CONSISTS OF six pulses, or "pips," of an audio tone and, apart from other times, it is radiated every weekday morning at nine o'clock. It is the sixth pip which indicates the instant of nine o'clock.

Smithy, who had entered the Workshop a little early, had switched on a radio he had repaired the evening before, and was now waiting for the Time Signal. He frowned as he looked first at his watch then at the Workshop clock, which was belatedly indicating ten to nine. Smithy was trying to remember if he had wound it before leaving the previous day.

As the first pip of the Time Signal sounded the door of the Workshop burst open to admit the hurtling figure of Smithy's assistant, Dick. Just as the sixth pip ended, not only were Dick's mackintosh and jacket hung on their hooks but he himself was stationed at his bench, soldering iron raised, white overall buttoned up, and ready for work.

"Morning, Smithy," he grinned after the echoes of his entry had died down.

"You only just made it," grunted the Serviceman by way of greeting.

"Perhaps so," said Dick pompously, "but you cannot deny that I have succeeded in achieving my correct position in the Terrestrial time-space continuum. My co-ordinates are nine of the clock, plus some seconds, and my locality the Workshop."

Smithy, who recognised the signs, groaned outwardly, but grinned inwardly.

"I see that your space-opera magazine arrived last night," he remarked unkindly. He wandered over to the clock to correct it.

"S.F.,"\* replied Dick, indignantly, "is not space-opera. My regular copy of *Astral Bodies* did arrive last night, if you must know, and I was up till two in the morning reading it. Hence the rush."

With mock horror he watched the Serviceman approach the clock.

"Smithy," he called out urgently. "Don't, for goodness sake, alter that clock. Who knows but that, by merely moving the hands, you might transport us into a different cosmos! In fact," continued Dick, warming to his theme, "one of the stories I read last night was about someone who deliberately set a clock wrong. After that everything went topsy-turvy. For instance, all the printing in books went from right to left instead of from left to right, and all positive quantities became negative. Very disturbing for those concerned."

"I think I'll risk it," said the Serviceman.

To Dick's astonishment, Smithy first of all advanced the Workshop clock to the correct time—a minute past nine—then deliberately advanced it a further five minutes.

Dick's next protest sounded almost genuine.

"Take it easy, Smithy. You never know whether there mightn't be something in these fantasy stories after all. Why, what you've just done may have conveyed us to a sphere where, instead of repairing television sets, people pay us to *stop* them from working.

"That mightn't be a bad idea at that," replied the Serviceman mysteriously. "Anyway, it somehow seems homely to work under a clock which is five minutes fast."

\* Science Fiction—Ed.

## The Ohm and The Mho

The Serviceman's action seemed to produce no immediate harmful effects, and he and his assistant soon settled down to their respective jobs; with the result that the Workshop became relatively peaceful. But Dick was not one to allow this state of affairs to continue for long.

"Hey, Smithy," he called out, breaking the silence after some ten minutes. "What on earth is a micromho?"

"A micromho," replied Smithy equably over his shoulder, "is one millionth part of a mho."

There was silence for a moment.

"Well, what's a mho?" persisted Dick.

Smithy left his work and walked over to his assistant's bench. Dick was gazing with a puzzled expression at a table of valve characteristics.

"Here's what I mean, Smithy," said Dick, pointing to a particular entry. "A valve type 6C4 is quoted here as having a transconductance of 2,200 micromhos. I don't get it."

"Transconductance," replied Smithy, "is just another word for mutual conductance. You don't see the word transconductance in English technical literature very often, but it pops up now and again. Mutual conductance, quoted in micromhos, appears rather more frequently."

"Yes, but what *are* micromhos?" asked Dick impatiently.

"I'll tell you," replied Smithy, drawing up a chair. "But first of all I will have to remind you of some of your very basic theory concerning resistance. Now, you yourself are pretty familiar with resistance because, being in the servicing game, you're bumping into it all the time. Also, you can express resistance in terms of voltage and current. Correct?"

"Resistance, in ohms," declaimed Dick, obligingly, "is equal to volts divided by amps."

"Right," said Smithy, "and the units of resistance—ohms, together with kilohms and megohms—are what people like ourselves deal with because they fit in with the sort of equipment which we handle. But engineers in other spheres of electricians find it much easier to work in terms of conductance rather than in terms of resistance. Conductance being the exact opposite of resistance, and being measured in mhos."

"That's funny," interrupted Dick, thoughtfully, "I've just noticed that the word mho is ohm spelt backwards. Just like what happened in that story last night."

"That's right," said Smithy blandly. "Also, I have to tell you that a mho is the reciprocal of an ohm."

"I see," replied Dick. "In other words,

ohms are equal to one over mhos. And vice versa, I suppose."

"You've got it," said Smithy. A resistance of 10 ohms is the same as a conductance of 1/10 mhos. Conversely, a conductance of, say, 100 mhos is the same as a resistance of 1/100 ohms."

"And two ohms," interrupted Dick quickly, "is equal to half a mho."

The Serviceman sighed.

"I *knew* you were going to make that crack," he remarked dolefully. "I have never yet been able to explain conductance to *anyone* without that half a mho gag coming up."

"Anyway, let's carry on to the business we started off with: the mutual conductance of valves. Now, we know that one method of evaluating the performance of a valve consists of quoting a figure for the change in anode current which is caused by a change in grid voltage, the anode voltage remaining constant. This is the mutual conductance, or gm, of the valve and we normally refer to it as so many milliamps per volt. Thus if, under a given set of conditions, we find that changing the grid potential of a valve by 1 volt causes a change in anode current of 4 milliamps, we say that the valve has a mutual conductance of 4 milliamps per volt under those conditions."

"I can understand that easily enough," said Dick, "but is it entirely necessary to change the grid potential by exactly one volt to obtain a figure for mutual conductance?"

"You've made a very good point there," said Smithy. "Sometimes it is desirable to measure the mutual conductance of a valve for a change in grid voltage which is much less than a volt. This is partly due to the fact that the mutual conductance itself may change whilst you are changing the grid voltage. For instance, if you want to work a valve with a very low input signal under conditions which could cause marked changes of mutual conductance for a change in grid voltage of one volt, you might get a false answer by taking measurements with such a big change. I'll give you an example. Here's the anode current—grid voltage curve (Fig. 1) of a valve which is working under special conditions. For certain reasons I want to bias this valve at -3 volts. Also, I am going to apply a very small signal input to it, something of the order of a few millivolts. That means that I want to know the mutual conductance of the valve under very small input conditions with -3 volts bias on the grid. This bias corresponds to point A on the curve I've just drawn."

"Now, one way of finding the mutual conductance from the curve *could* consist of moving the grid voltage either side of -3 volts by half a volt, thereby giving me an

overall change in grid potential of one volt. If I try this on the curve I've drawn I get points B and C. Point B corresponds to 0.8 milliamps anode current and point C to 4.4 milliamps anode current. So my change in anode current for one volt change in grid potential is 3.6 milliamps, this being also the figure, in milliamps per volt, for its mutual conductance.

"However, the result we've just obtained will not help us a great deal in this particular instance, where we only intend applying a small input signal. Let's check what happens, therefore, if we see what change of anode current we get for a much smaller change in grid potential. This could be, say, one tenth of a volt. Our process of finding mutual conductance from the curve now results in

"This is rather interesting," said Dick. "I don't know whether you're keeping something up your sleeve, Smithy, but there's something I've spotted straight away. In practice, first of all, we are already assuming the obvious fact that if you were designing a piece of gear using the valve in question you wouldn't go through the business of actually measuring mutual conductance with meters and things. Instead, you'd work with the curves given by the manufacturer, as you've just done. Secondly, if you wanted to work a valve under the conditions you've just mentioned you wouldn't normally try to read from the curve the difference given by tiny variations in grid voltage because it would be difficult to read the resulting small changes in anode current without error. So, in this

Fig. 1. Several methods of finding mutual conductance from an anode current-grid voltage curve. The solid line represents a tangent drawn to the curve

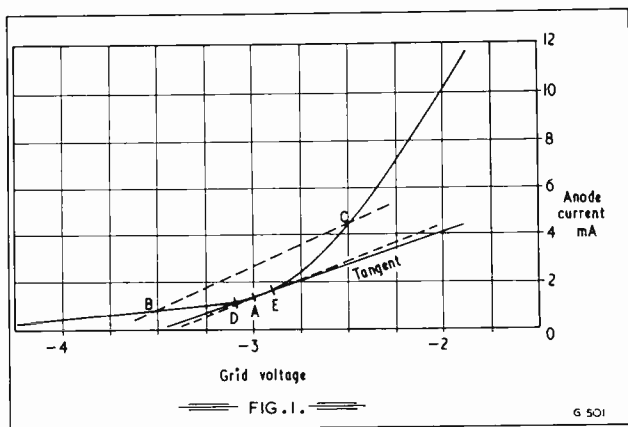

our moving the grid potential by one-twentieth of a volt on either side of  $-3$  volts, and seeing what change in anode current we get. That is, we work at points D and E on the curve. The two anode currents we now get are (so far as we can read them, because they are very close together on the curve) 1.25 milliamps and 1.55 milliamps respectively; this giving us a change in anode current of 0.3 milliamps. But 0.3 milliamps is the anode current change given by a grid change of only one-tenth of a volt, so, if we want to express it in milliamps per volt we have to multiply it by ten. The mutual conductance figure then becomes 3 milliamps per volt. Which is somewhat different from the previous figure of 3.6 milliamps per volt.

"Just for fun, I'll draw straight lines between points B and C and points D and E and continue the latter out a little so that you can compare them. As you can see, the two lines represent quite different states of affairs."

particular instance, you could employ another method of attack. This would consist of drawing a straight line such that it only touched the curve at point A. In other words, nothing more nor less than a tangent."

Whereupon Dick drew a tangent on Smithy's curve.

"There you are," said Dick. "I can now read very easily, from my tangent, the mutual conductance existing at point A, because my tangent has the same slope as the curve has at this point. If, using the tangent, I check the anode currents for, say,  $-3$  and  $-2$  volts at the grid, I get an anode current change of 2.6 milliamps. So the mutual conductance at point A is 2.6 milliamps per volt, this figure having been obtained quickly and easily. Also, it is more accurate than that given by your own line DE."

"Dick," beamed Smithy, "I'm proud of you. Never again shall I doubt your ability

to pick things up quickly. Or not very often, anyway.

"Right. Now the conditions we have been discussing apply to the case where we are applying a very small input voltage to the valve, the grid bias being such that the anode current-grid voltage curve is quite curved at the point where we wish to operate. It frequently happens that we want to work a valve at a point where the anode current-grid voltage curve is almost straight, and it is quite possible that we may also want to apply a hefty input signal."

each case. However, at the accuracy we're working to here, they all come out to the same value."

"You're leading up to something here," said Dick suspiciously. "I said you had something up your sleeve."

"And so I have," chuckled the Serviceman. "Because, whatever grid voltage change I have made I have always had to find the mutual conductance in milliamps per volt by dividing the change in anode current by the change in grid voltage. Thus when, just now, I made a grid current change of 2 volts the

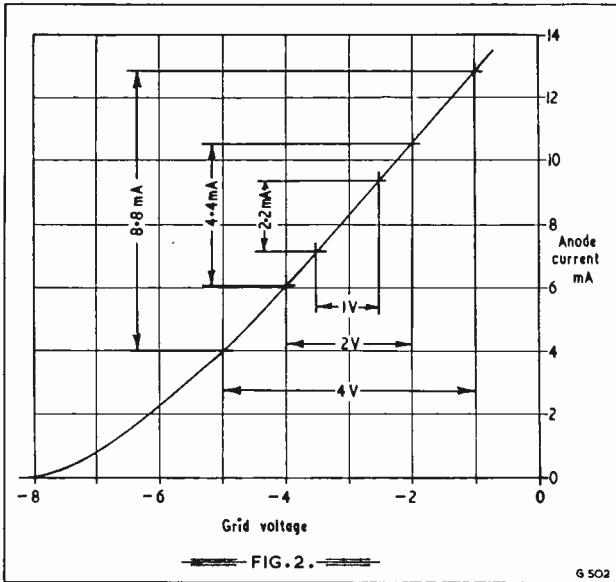

Fig. 2. If the anode current-grid voltage curve is relatively straight, mutual conductance readings will be similar for varying changes in grid voltage

Smithy drew a second curve (Fig. 2).

"In this case our curve is so straight," the Serviceman continued, "that we can find our mutual conductance by checking anode current change for one volt, two volts, or even four volts change. For one volt change we get an anode current change of 2.2 milliamps, so the mutual conductance is 2.2 milliamps per volt. With a two volt change the anode current changes by 4.4 milliamps, so that the mutual conductance is 4.4/2 milliamps per volt, which is equal to 2.2 milliamps per volt. For four volts change we get a mutual conductance of 8.8/4 milliamps per volt, which brings us back once more to our initial figure of 2.2 milliamps per volt. If we had measured our changes in anode current to more than two significant figures we might have found small discrepancies between the mutual conductance figures in

mutual conductance was 4.4/2 milliamps per volt. Earlier on, when I made a grid voltage change of one-tenth of a volt, the mutual conductance was  $\frac{0.3}{1/10}$  milliamps per volt, which is, of course, equal to 0.3 x 10, or 3 milliamps per volt."

"I see," said Dick, frowning, as he concentrated. "What you mean is that the mutual conductance of the valve is actually I/E, where I is the change in anode current and E the change in grid voltage."

"Exactly," said Smithy. "Now what's a mho in terms of I and E?"

"Well," said Dick slowly, "to start off with an ohm is E/I, as we said earlier. A mho is a reciprocal of an ohm so a mho, therefore, must be equal to I/E. Am I right?"

Smithy nodded.

"Fair enough," continued Dick. "Now



we have also got round to the point that the mutual conductance of a valve is, similarly,  $I/E$ ."

"Keep going," said Smithy. "You might find things easier if you next bring all your currents up to amps."

"Righto," said Dick. "I would also like to carry on with an actual example because I find it easier that way. Let's assume that a valve has a mutual conductance of 4 milliamps per volt. Now, substituting figures for  $I$  and  $E$ , and bringing the milliamps to amps I can next say that the mutual conductance of this valve is 0.004/1 amps per volt. Right?"

"Right."

"But," carried on Dick, " $I/E$  where  $I$  is in amps and  $E$  is in volts, is also the formula for mhos. So, can I now say that the mutual conductance of my valve is 0.004/1 or, simply, 0.004 mhos?"

"You can."

"Ah," said Dick a little excitedly, "I see it all now. Carrying on back to the 'millis' and 'micros,' then, my mutual conductance of 0.004 mhos is equal to 4 millimhos and is equal to—let me think—4,000 micromhos."

"Precisely," commented Smithy. "Now how about tackling your original mutual conductance of 2,200 micromhos?"

"Well," said Dick, "if 4,000 micromhos is the same as 4 milliamps per volt, then 2,200 micromhos must be the same as 2.2 milliamps per volt. In other words, divide mutual conductance in micromhos by 1,000 and you get the answer in milliamps per volt."

"You've got it," said the Serviceman.

### Negative Resistance

He glanced at the Workshop clock, which now indicated half-past nine. Dick followed the movement of his eyes.

"I wish," Dick remarked, a little worriedly, "I could get that silly story I read last night out of my mind. I mean to say, you didn't have to set the clock wrongly this morning, but you did. Nor did I have to read words like ohm spelt backwards, but I did. You know, I'm beginning to feel that this is going to be rather a *weird* morning."

"You're letting your imagination run away with you," chuckled Smithy. "That's what comes of reading fantasy in the early hours. Anyway, whilst we're talking about resistance, I think I ought to pass on some more information on this subject."

"What sort of resistance do you want to talk about?" asked Dick.

"Negative resistance," intoned Smithy.

"Ye gods," muttered his assistant.

"Yes," continued Smithy firmly, "negative resistance. Which occurs not when  $R$  equals  $E/I$  but when  $R$  equals *minus*  $E/I$ ."

He glanced enquiringly at his assistant, but Dick had given himself up to a troubled silence.

"Another way of putting it," Smithy carried on, "is to say that negative resistance appears when an increase in current results in a *decrease* in voltage. In some instances, if you connect a tuned circuit up to something having negative resistance it starts oscillating straight away."

"That sounds intriguing," said Dick, forgetting his worries for a moment.

"A typical example of this happening," said Smithy, "is in the dynatron. A dynatron uses a circuit like this."

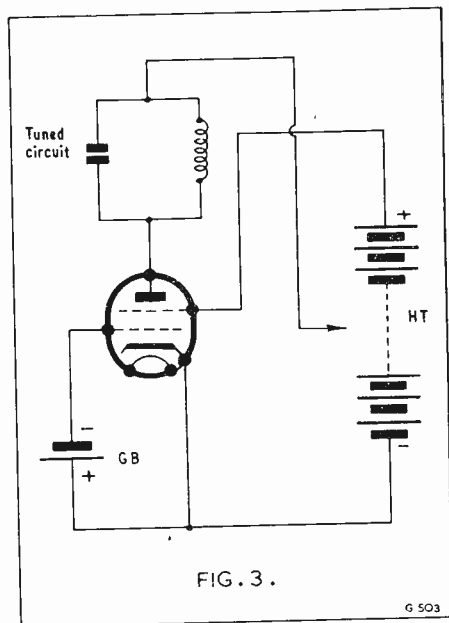

Fig. 3. The dynatron

Smithy scribbled on the paper in front of (Fig. 3).

"Now you will see that, in this circuit, I have shown the h.t. supply as a battery," he stated. "The reason being that I want to emphasise the fact that the screen grid of the valve connects to an h.t. supply whose potential is higher than that to which the anode is connected."

"Before proceeding further I think we should take a very quick look at the anode voltage—anode current curve given by a normally-connected valve. The curve you get is usually something like this. (Fig. 4 (a).) There's nothing at all out of the way in this

curve; all it tells us is that as the anode voltage increases the anode current increases also. Which is what you would expect.

“However, with the dynatron circuit you get a curve like this. (Fig. 4 (b).) To understand why the queer kink occurs in this curve it is best to start off by considering what happens at a low anode voltage, such as occurs at point P. At point P the anode voltage is considerably less than the screen grid voltage, but this still does not prevent a quantity of electrons from the cathode reaching the anode and causing an anode current to flow. As we increase anode voltage, proceeding along towards point Q on the curve, the anode current similarly increases. Which is, again, just what you would expect.

electrons to be knocked out, whereupon these may leave the body. It is quite possible for a single electron to cause many secondary electrons to leave the body. Also, all else being equal, the number of secondary electrons knocked out by a single primary electron increases when the speed with which the latter strikes the body increases.

“As we approach point Q on our dynatron curve, we are both increasing the velocity of the electrons striking the anode, and their quantity. Quite a number of the secondary electrons are attracted towards the positively charged screen grid, whereupon they become lost by the anode.

“When we reach point Q the curve ceases to climb. At this point the number of extra electrons which would flow through the

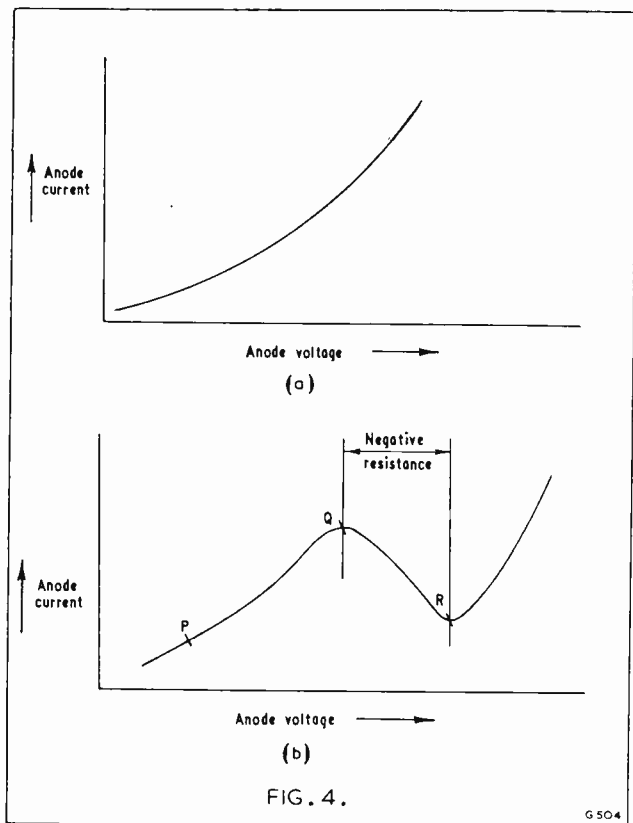

Fig. 4 (a) Anode current-anode voltage curve of a normally connected valve. Fig. 4 (b) The anode-current-anode voltage curve of a dynatron

“Now, whilst the anode voltage is increasing, a second effect becomes prominent. As you should know, when an electron strikes a body such as an anode it causes secondary

anode-cathode circuit if a very small increase in anode voltage were to occur is equalled by the number of extra secondary electrons which would flow in the reverse direction,

through the anode-screen grid circuit. As we further increase the anode voltage, going past point Q towards point R, the increase in the secondary electron current now becomes greater than that in the anode-cathode circuit, and the overall anode current descends. The curve continues to descend until the anode voltage reaches point R. At R the anode potential is such that the screen grid offers less attraction to the secondary electrons, whereupon more of these return to the anode. After point R the increase in secondary electron current for a small change in anode voltage is less than the increase in the current which flows in the anode-cathode circuit, and the total anode current behaves in normal fashion."

"Phew," remarked Dick. "I hadn't realised that things like that could happen in simple circuits like the one you've just drawn. It seems almost like necromancy to take an ordinary bottle, apply nothing to it other than potentials, and yet get it to exhibit negative resistance like that. The bit that I find most fascinating is that you simply pop a tuned circuit in series with the valve, using no feedback circuits at all, and it just oscillates!"

"Provided you apply the right potentials," qualified Smyth. "Whereupon it oscillates quite well and reliably. You will note that I used a screen grid valve in my circuit. In a pentode, the suppressor grid between the anode and screen grid is inserted purposely to prevent the secondary electrons from the anode reaching the screen grid. And the negative resistance effect disappears."

"Well, that's something of a relief," stated Dick. "I might have a few back-to-front micromhos wandering around in the sets I service but at least I don't have any upside-down negative resistances to handle."

"Oh, but you do," remarked the Serviceman. "One of the most obvious examples being the thermistor in series with most heater lines. The greater the current which flows through a thermistor the less the voltage developed across it. And if that isn't an example of negative resistance I don't know what is."

#### Time Factor

"Is that all you have to say about negative resistance?" asked Dick.

"It is," replied Smyth gravely.

"Then thank goodness for that," said Dick with relief. "I'm now going to get back to some good old practical servicing."

"But aren't you going to boil the kettle for tea?" asked the Serviceman seriously. "It's gone eleven o'clock."

Dick looked wildly at the Workshop clock, now indicating 9.32, and at the watch Smyth showed him, which indicated five past eleven.

"This is the end," he gulped wildly. "O.K., Smyth, I'll make the tea if that's what you want me to do. But I'm going to say right now that there's something seriously *wrong* with things this morning. If this is what happens when the Workshop and science fiction become muddled together, then from now on I'm going to drop science fiction. Or the Workshop!"

Which only goes to show what confusion can be caused when a run-down Workshop clock has stopped for some time at 9.32, and a far from guileless Serviceman surreptitiously advances his watch by an hour or so (even if it does mean having tea a little earlier than usual).

And, of course, Smyth would never have confessed that he, also, had received his own copy of *Astral Bodies* the night before!

---

## Sorry, No More Room!

Grafton Radio Society (G3AFT) announce that with over seventy applicants for their well-known R.A.E. and Morse classes, they regret no more applications can be considered. The club meetings, held on Friday evenings at Montem School, Hornsey Road, Holloway, London, N.7 (just off Seven Sisters Road) with slow Morse at 7 p.m., the usual club lecture, talk, discussion, quiz, junk sale, etc., at 8 p.m. until 10 p.m., are open to new members and to visitors. In addition, the club operates two transmitters covering all bands from 160m to 10m. Hon. Sec.: A. W. H. Wennell, G2CJN, 145 Uxendon Hill, Wembley Park, Middlesex.

---

## Nottingham Hi-Fi and Tape Club

A new club has been formed at Nottingham for hi-fi enthusiasts and tape recording fans.

Meetings are held at 7.30 p.m. every Wednesday at Woodthorpe House, Mansfield Road, Nottingham.

Activities will include discussions, talks, and demonstrations of audio equipment, as well as practical work involving the use of tape recorders, record players, etc. If there is sufficient demand, lectures and talks of a technical nature will be organised. It is also intended to lay on visits to places of interest to audio fans, exhibitions, etc.

Enquiries should be made to N. D. Littlewood, c/o the above address or at 129 Standhill Road, Nottingham.

# UNDERSTANDING TELEVISION

PART 11

By W. G. MORLEY

*The eleventh in a series of articles which, starting from first principles, describes the basic theory and practice of television*

**I**N LAST MONTH'S ISSUE WE INTRODUCED THE r.f. amplifier, as employed in modern television tuners. We discussed the cascode circuit arrangement and showed how this is employed with aerial coils of the double-winding transformer type. We shall now carry on to the more recently introduced single winding aerial input circuits.

Owing to space limitations, part of last month's article has been carried forward to form the commencement of this month's contribution. In consequence, it will be found that reference is made occasionally to diagrams which were published in the previous issue.

### Single Winding Aerial Circuits

In the United States it has been conventional practice for the last few years to employ a single winding aerial coil instead of the double-winding r.f. transformer shown in Fig. 57. Single winding aerial coils are to be seen, also, in some British tuners.

Single winding aerial coils are used in a circuit of the type shown in Fig. 60 (a). In this diagram the coil operates in a simple pi circuit, the tuning capacities consisting of the condenser  $C_1$  and the capacity to chassis given by the first triode. The input condenser normally has a value (according to tuner design) lying between 20 and 40pF, whilst the input capacity of the valve is of the order of 2-3pF. In consequence the circuit functions

in the same manner as would occur if there were an "earthy" tap near that end of the coil which is remote from the grid. The result is that a voltage step-up effect takes place. By suitable choice of input condenser value it is, therefore, possible to match the impedance of the aerial feeder to the input impedance of the valve.

It is usual to employ neutralising in practical cascode circuits, and this process is carried out in single winding input circuits by fitting a condenser between the anode of the first triode and that end of the aerial coil which is remote from the grid. See Fig. 60 (b). This condenser then provides neutralisation in the same manner as did  $C_1$  in Fig. 57. In cases where it is intended to apply an automatic gain control voltage to the cascode, this may be applied via a grid leak, as in Fig. 60 (c). In such an instance it becomes necessary to insert a d.c. blocking condenser at some point between the input condenser  $C_1$  and the grid of the valve. So far as its d.c. blocking effect is concerned, this condenser may be fitted at either side of the coil. In Fig. 60 (c) it is inserted in the grid side of the coil.

A disadvantage with the pi-type input circuit is that it does not offer as great a degree of rejection to frequencies other than the signal frequency as does the r.f. transformer input circuit. Any signals picked up by the aerial which fall close to, or within,

Fig. 60 (a) The basic circuit around a single winding aerial coil.  $C_1$  and the input capacity of the valve tune the coil in a conventional pi arrangement. (b) Neutralising may be obtained by adding  $C_2$ . (c) A grid leak and d.c. blocking condenser are fitted, thereby enabling an a.g.c. voltage to be applied to  $V_1(a)$ . (d) Finally, to overcome the relatively poor rejection of a pi tuned circuit to frequencies other than the resonant frequency, a simple absorption i.f. rejection circuit is added

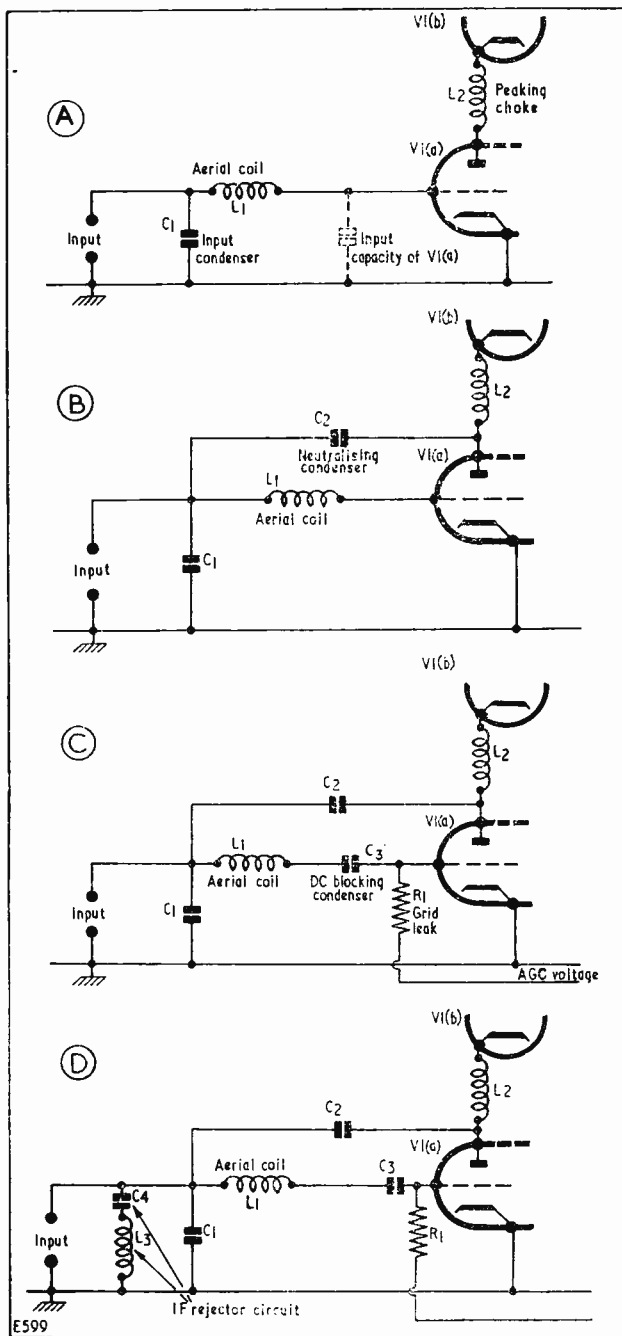

the intermediate frequencies of the television receiver are particularly liable to cause interference, especially when the tuner is switched to a low channel (whose frequency would be close to the intermediate frequency). In consequence, when a single winding aerial circuit is employed it is customary for an i.f. rejection circuit to be fitted as well. Such a circuit is illustrated in Fig. 60 (d) and, as may be seen, it consists quite simply of a series tuned circuit made up by a coil and condenser connected across the input condenser. Normally, the coil is adjusted by means of a core until the rejection circuit resonates at the desired frequency. The circuit then absorbs energy at the frequency to which it is tuned, thereby reducing the amount of interfering signal at this frequency, which is passed on to the grid of the cascade.

considerable number of advantages, and these are of sufficient importance to make its use extremely attractive. One of these advantages is that only two connections are needed to the coil itself. In practical turret designs this results in a valuable reduction in the number of contacts required for connection between the chassis assembly and the aerial coils, with a consequent reduction in space requirements, mechanical design problems, and cost. A further advantage is that, since there are now no coupling windings, the single winding coils may be made self-supporting, thereby obviating the necessity for coil formers and cores. In its self-supporting form the inductance of the aerial coil can be adjusted by opening or closing its turns, the wire of the coil being sufficiently rigid for these to remain in

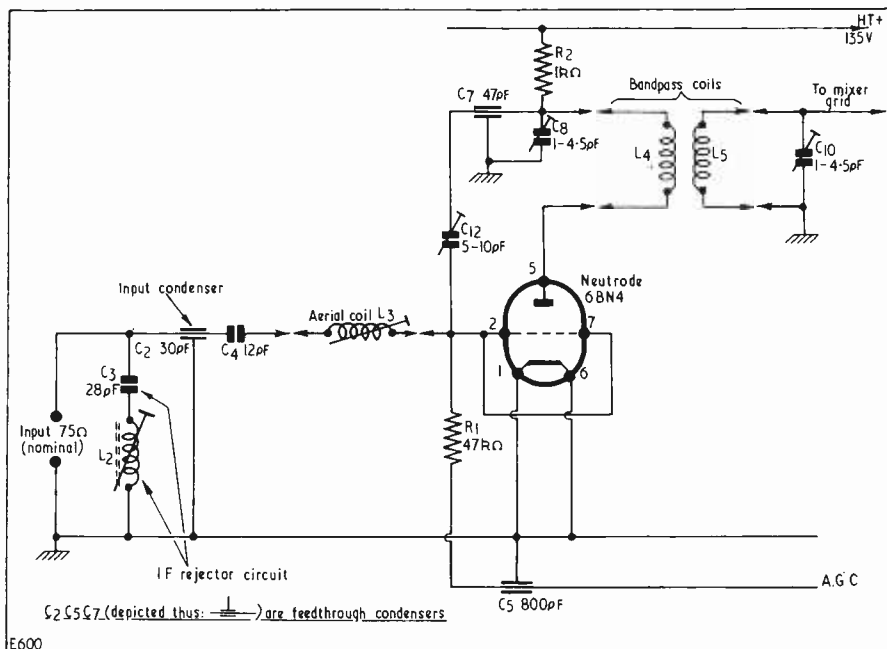

Fig. 61. The circuit employed around the Neutrode in the Standard Coil Products ND 4000 series of turret tuners. A balun and an extra i.f. rejector circuit (needed due to the small amount of spacing between the standard American i.f. and lowest channel signal frequency) are employed between the aerial input and the 75 ohm input terminals shown here. The component number suffixes are those employed in the full Standard Coil Circuit. The connection to the mixer grid is via a 47pF condenser

We have just noted that the single winding aerial circuit suffers from the disadvantage of requiring an additional i.f. rejector circuit. At the same time, however, it offers a

position after this operation has been carried out.

#### The Neutrode

In a number of current American tuners,

a cascode is not employed as r.f. amplifier. Instead, a valve described as a *neutrode* is used. The Neutrode is a single triode having a low anode-grid capacity which has been specifically developed for television tuner applications. In order to keep lead inductances low, both grid and cathode of the Neutrode have double lead-out wires. The Neutrode appears as type 6BN4—for 6.3 volt heater operation—or as types 2BN4 and 3BN4 when series heater lines are employed.<sup>1</sup>

Despite its low anode-grid capacity, the Neutrode still requires neutralisation. In this case neutralising is too critical for fixed components to be employed, and a means of adjustment is essential. A typical neutralising circuit is illustrated in Fig. 61, this being the arrangement employed in the ND-4000 series of Neutrode tuners manufactured by Standard Coil Products Co. Inc.

In Fig. 61 the circuit before the grid of the Neutrode employs a single winding aerial coil, similar to that of Fig. 60 (d). The anode of the Neutrode connects into the first of two coils which are coupled together to form a bandpass tuned circuit, as in the block schematic diagram of Fig. 51. The second of these coils couples into the mixer input circuit. (We shall be dealing with the bandpass coil section of the tuner in next month's article). The two condensers  $C_8$  and  $C_{10}$  are low-value trimmers whose purpose is that of ensuring that all production chassis present the same tuning capacity to the coils.

An interesting feature of the circuit of Fig. 61 is that the necessary 180 degree phase reversal of anode voltage needed for neutralisation purposes is provided, not by the aerial coil as in Figs. 57 and 60 (b), but by the coil in the anode circuit. This coil,  $L_4$  of Fig. 61, is decoupled to earth via  $C_7$ . However, the value of  $C_7$  is made sufficiently low for a small proportion of the signal frequency voltage to appear across it. This signal frequency voltage is then applied to the grid of the Neutrode via the trimmer  $C_{12}$ , this latter being the component which is adjusted for optimum neutralising.

The main advantages offered by the Neutrode when compared with the cascode r.f. amplifier are that it requires fewer components, that it can work with a lower h.t. voltage, and that it dissipates less power. The fact that a lower h.t. voltage is required is of value in American receivers of the a.c./d.c. transformerless type as, unless a voltage doubling rectifier arrangement is used, the rectified h.t. voltage available is limited to some 135 volts because of the standard a.c. mains voltage of 117 volts.

<sup>1</sup> New Circuits in TV Tuners, by E. D. Lucas, Jnr., *Radio-Electronics*, August, 1958. Details for the circuit given in Fig. 61 have also been taken from this reference.

The Neutrode is designed to operate from an h.t. supply of 135 volts. The feature of less dissipation of power is valuable not only because it is, in any event, always desirable to keep down h.t. current in a television receiver, but also because less power dissipation results in the generation of less heat, an important factor when miniaturised layouts are employed. The r.f. gain provided by the Neutrode is lower than that given by the cascode. (It is stated that the Neutrode offers better a.g.c. characteristics than does the cascode.)

### 300 Ohm Inputs

In our discussion of tuner aerial circuits in this and the preceding article we have seen examples wherein the input from the aerial was provided via 75 ohm coaxial feeder. As one conductor of 75 ohm coaxial feeder is connected to chassis at the receiver (and thence to earth) this type of feeder is referred to as "unbalanced."

Fig. 62 (a) illustrates the method by means of which 75 ohm coaxial feeder couples to the input tuned circuit of the television tuner where an r.f. transformer type of aerial coil is employed. Although 75 ohm feeder is very common in British installations it is rarely employed for such purposes outside the U.K. Instead, 300 ohm feeder is used.

A typical input circuit for 300 ohm feeder is shown in Fig. 62 (b). It will be seen that in this case the input coil has a centre tap which connects to chassis, and that the two conductors of the feeder connect to the outside ends of the coupling coil. Since the two conductors of the feeder are now balanced about chassis (and, thence, about earth) this type of feeder is referred to as "balanced."

Due to the fact that, for impedance matching purposes, the turns ratio of a transformer is equal to the square root of the impedance ratio it matches, the 300 ohm coupling winding of Fig. 62 (b) has twice the number of turns as has the 75 ohm winding of Fig. 62 (a). (The square root of the impedance ratio 300:75—which is equal to 4:1—is 2:1.) This assumes, of course, that the secondary windings and circuits of Figs. 62 (a) and (b) are similar. Because of this simple 2:1 turns relationship between coupling windings intended for 300 and 75 ohm inputs, it is quite possible for the coupling winding of Fig. 62 (b) to accept a 75 ohm coaxial input, this being connected either across points A and B, or across points B and C. In either case, the outer conductor of the coaxial input would be connected to point B.

When single winding pi-tuned circuit inputs are used in the aerial stage, a different technique has to be employed if a 300-ohm-

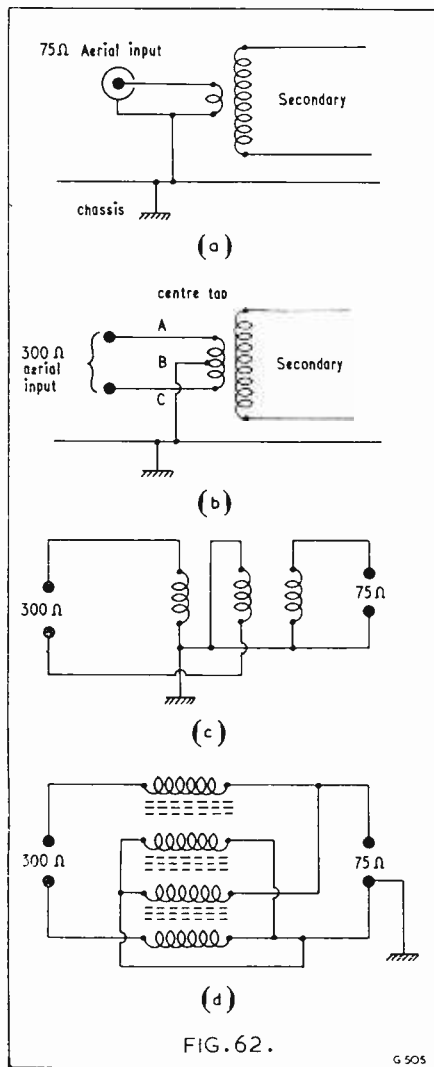

FIG. 62.

Fig. 62 (a) A 75 ohm input circuit. (b) A centre-tapped input winding is employed for 300 ohm input feeders. (c) A simple 300-ohm-balanced to 75-ohm-unbalanced balun. The three windings have the same number of turns and are tightly coupled together. (d) A more complex balun of the type employed in current tuners

whereupon a direct connection to the balanced feeder becomes impossible. The solution to this problem consists of employing a balun.<sup>2</sup> A simple 300-ohm-balanced to 75-ohm-unbalanced balun is depicted in Fig. 62 (c). This balun could be inserted between a 300-ohm-balanced aerial-feeder and a single winding aerial circuit having an input impedance of 75 ohm. For good operation the three windings of the balun of Fig. 62 (c) must be coupled together very tightly indeed. In practice, baluns of the type employed in television tuner units have slightly more complex circuits, an example being shown in Fig. 62 (d). Arrangements of this type ensure optimum mutual coupling between the various parts of the winding whilst still retaining the necessary 2:1 turns ratio. These baluns usually employ only a few turns of wire and are wound on special low-loss ferrite cores.

### Aerial Isolation

When, as is common practice, television receivers work from transformerless power supplies, care has to be taken to ensure that the aerial connections are adequately isolated from their consequently "live" chassis in order to prevent accidental shock. The conventional method of obtaining isolation consists of connecting condensers in series with both input leads. As it is possible for an aerial to acquire high potential static charges, it is also necessary to provide a leakage path between the input feeder connections and the chassis of the receiver. Such a leakage path may be given by connecting one or more high value resistors between the aerial feeder and the receiver chassis.

Typical aerial isolating circuits are illustrated in Figs. 63 (a) and (b). That of Fig. 63 (a) would be employed for 300 ohm and 75 ohm inputs, although many 75 ohm inputs nowadays use the arrangement of Fig. 63 (b).

In Britain, special requirements for aerial isolation are laid down in British Standard 415:1957.<sup>3</sup> One of these requirements is that the maximum leakage current which can be allowed to flow to earth from the aerial terminal, or group of terminals, is 0.3mA. In order to meet this requirement many of the more recently manufactured British television receivers employ the isolation circuit of Fig. 63 (b), the resistor  $R_2$  having a value of  $2M\Omega$ , and the series condensers values of 470pF. The resistor  $R_1$  may have a value of 1 or  $2M\Omega$ .

<sup>2</sup> A balun is a transformer whose function it is to match a balanced input to an unbalanced output or vice versa. The term is derived from the phrase: *balance to unbalance*.

<sup>3</sup> British Standard 415 : 1957. *Safety Requirements for Radio or other Electronic Apparatus for Accoustical or Visual Reproduction (Electric-mains-supplied)*.

balanced input is intended. The difficulty here is that one side of the input to the single winding circuit must be at chassis potential,



### The Bandpass Circuit

A very important part of the television tuner is the bandpass circuit which couples the r.f. amplifier to the grid of the mixer valve. In company with the aerial tuned circuit it is the function of the bandpass circuit to provide a response which ensures that the desired vision and sound signals are received without undue attenuation of any part, and that adequate selectivity against interference from transmissions on adjacent channels is provided. Without going into too much detail at this stage it would be interesting to quickly examine the response of practical bandpass tuned circuits, and to see how they fit into the overall response of the tuner. To give an instance of what is required of television tuners, let us consider the ideal transmitter characteristic on any channel in the British 405 line system. Fig. 64 illustrates this characteristic.<sup>4</sup> As may be seen, if both the vision and sound signals are to be correctly presented to the i.f. stages of the associated television,

<sup>4</sup> The information given in Fig. 64 is taken from Fig. 20 and Table 2 of *Understanding Television*, part 4, published in the April 1958 issue.

Fig. 63 (a) A simple aerial isolation circuit, used when the associated receiver has a transformerless power supply. (b) An alternative isolation circuit, frequently employed for 75 ohm inputs

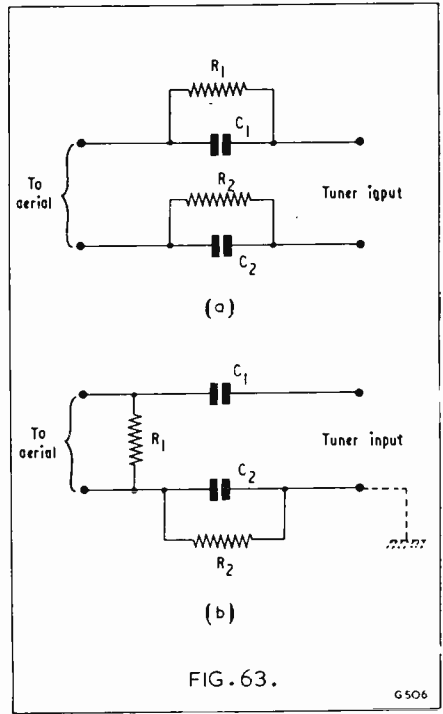

FIG. 63.

G506

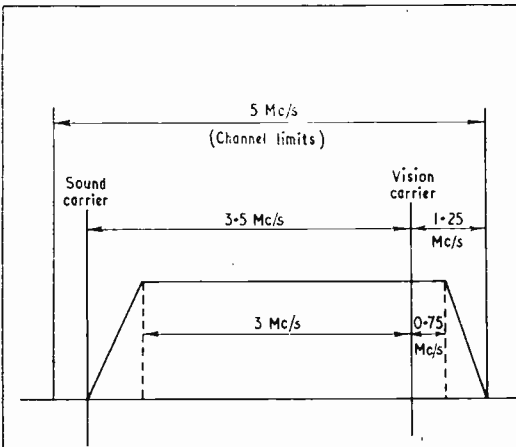

FIG. 64.

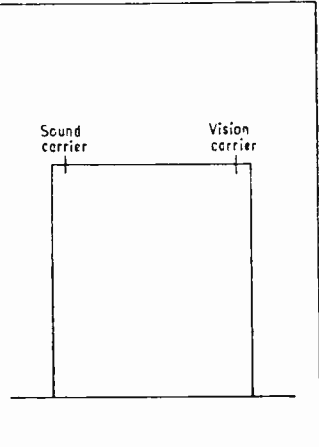

FIG. 65.

G507

Fig. 64. The ideal transmitter characteristic for any channel in the British 405 line system. Fig. 65. An ideal tuner response would have an appearance similar to that shown here

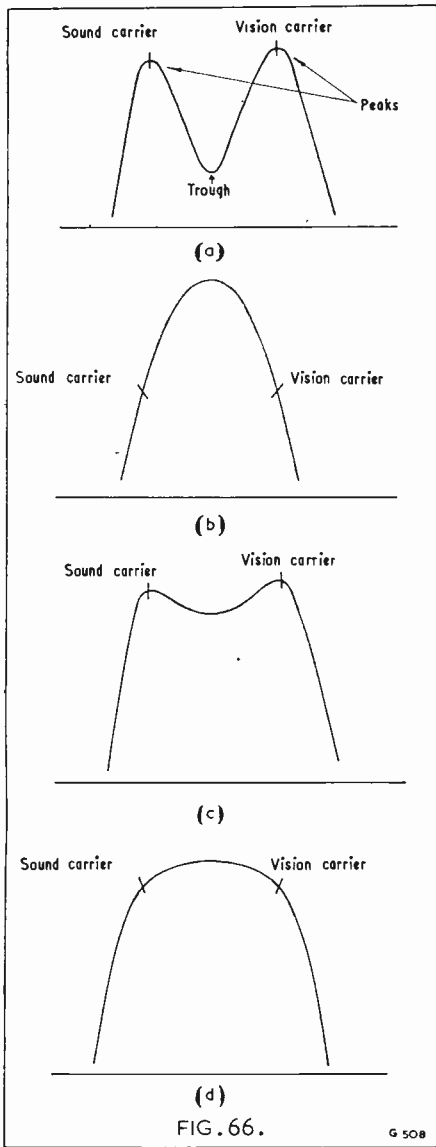

Fig. 66 (a) An example of the response given by the bandpass coils of a television tuner. (b) The response given by the aerial tuned circuit. (c) The overall response of a tuner unit is a combination of the bandpass and aerial responses. (d) The aerial tuned circuit response may sometimes cause the overall response to take up the form shown here

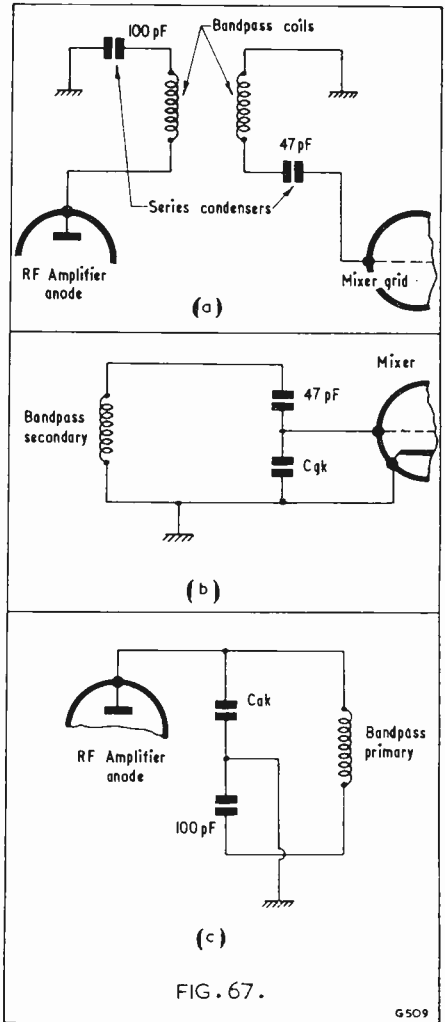

Fig. 67 (a) A bandpass circuit illustrating the relatively low value condensers which are inserted in the primary and secondary tuned circuits. The values given are typical of current tuners. (b) Due to the presence of the 47pF condenser in the secondary tuned circuit, the grid of the mixer valve taps into the capacitive section of the tuned circuit. (c) In similar fashion, the 100pF condenser in the primary circuit causes the anode-chassis output of the r.f. amplifier to tap into the capacitive half of the primary tuned circuit

tuner has to have a response which passes, without undue attenuation of any part, a range of frequencies lying between the sound and vision carriers. An ideal tuner response would take up a form something like that shown in Fig. 65.

The response given by the bandpass coils of most television tuners usually assumes an appearance like that of Fig. 66 (a). This response has the familiar double-peak form peculiar to bandpass tuned circuits, and the highest points on the two peaks are intended to lie close to the vision and sound carriers.<sup>5</sup> A typical response for the aerial tuned circuit of a tuner is shown in Fig. 66 (b). Since the aerial input circuit employs only one tuned circuit, a single peak occurs.

The overall response of the tuner is that given by both the aerial and bandpass tuned circuits, and it is normally similar to that of Fig. 66 (c). This is a combination of the responses of Figs. 66 (a) and (b), and it will be noted that the single peak of Fig. 66 (b) causes the trough between the peaks of Fig. 66 (a) to be raised by quite an appreciable amount. As may be seen, the overall response begins to approach the ideal curve of Fig. 65. In some cases (or on some channels in a particular tuner) the effect of the aerial tuned circuit is greater than occurs in Fig. 66 (c).—When this happens the centre of the bandpass response is raised so much by the aerial response that the final response assumes the shape shown in Fig. 66 (d). Such a response is quite satisfactory, provided that the points at which the vision and sound carriers appear are not too low when compared with the highest part.

<sup>5</sup> According to the design of the tuner, the peaks may be positioned either slightly inside or outside the carriers.

The above paragraphs are intended only to introduce the effect that the bandpass tuned circuit has on the overall tuner response. We shall examine the subject of overall response in more detail later, after we have discussed the mixer stage and its test points.

Before concluding on the subject of bandpass coils it should be mentioned that these are normally coupled to their appropriate valves via condensers having values which are lower than those normally chosen for decoupling purposes. A typical example is given in Fig. 67 (a), wherein a 47pF condenser is connected between the secondary coil and the grid of the mixer valve, and a 100pF condenser is connected in series with the primary coil and chassis. The purpose of these condensers is that of ensuring that the input impedance of the mixer and the output impedance of the r.f. amplifier do not cause excessive damping of the tuned circuits. The condensers ensure that the grid of the mixer and the anode of the r.f. amplifier connect to taps in the capacitive parts of the tuned circuits, the positions of these taps being governed by the values of the series condensers. Fig. 67 (b) and (c) may help to illustrate the effect more clearly. The values chosen for the bandpass series condensers in practical tuners are those which offer the best compromise between minimum damping of the bandpass coils and maximum transference of signal frequency voltage from the anode of the r.f. amplifier to the grid of the mixer valve.

## Next Month

In next month's contribution we shall carry on to the mixer and oscillator sections.

# Can Anyone Help?

*Requests for information are inserted in this section free of charge, subject to space being available*

**R.1426 Receiver (Modified 1355).**—M. Ivings, 359 Rocky Lane, Great Barr, Birmingham 22A, wishes to obtain any possible information, particularly connections to the 12-pin Jones plug, and is willing to purchase manual or circuit diagram.

**R.107 Receiver.**—V. A. Davies, 154 Frampton Road, Penyrheol, Gorseinon, Swansea, would like to buy or borrow the service manual or any data.

**Amplion Six Receiver.**—J. Roberts, 15 Sambrook Road, Fallings Park, Wolverhampton, Staffs, wishes to buy or borrow details of this 6-valve a.c. mains receiver, and will promptly acknowledge all letters.

**Marconi Communications Marine Receiver 352 (A).**—W. Stephenson, 5 Clifton Road, Birkenhead, Cheshire, appeals for any data and the circuit diagram, and will gladly defray any expenses.

**Transmitter/Receiver Sets 18 Mk. 3 and 17 Mk. 2.**—P. Dawson, 411 Oxford Street, London, W.1, would like to purchase or to borrow the circuit diagram and details.

**34-38 Mc/s Discriminator.**—J. W. Fuzzard, Athelstan, Chapel Enlfrith, Stockport, Cheshire, has a home-built radio/t.v. receiver using a Cydon turret tuner for 34-38 Mc/s i.f. Can any reader suggest a source of supply for a 34-38 Mc/s Discriminator, since he wishes to add I.m.?

**MCR.1 Miniature Communications Receiver.**—G. Clarke, c/o Harmony Productions Pty. Ltd., 123 Blagowiah Road, Fairlight, Sydney, New South Wales, Australia, asks if any reader can supply him with the circuit of the MCR.1 and its a.c./d.c. power supply unit.

**Philco Signal Generator Model 778.**—P. J. G. McAvera, Ballymacnamee, Portlaffery, Co. Down, N. Ireland, wishes to obtain on sale or loan any literature, data or service manual. Manufactured in 1934, the makers can no longer supply details.

**Ferguson Model 951T, T.V. Receiver.**—H. F. Walker, 8 Gladstone Road, Dorrige, Solihull, Warwickshire, wishes to buy or borrow a service sheet for this 9in model which has a fault in the picture circuit.

# radio

# miscellany

**T**HIS MONTH I STILL FIND MYSELF HAVING to write from a hospital bed, but there's every hope I shall be back to normal shortly. Once again there are a number of nice letters from readers, so I am hardly at a loss for topics. Indeed, the difficulty may be covering them all. First our old friends, the Bedfast amateurs. Their September *Radial* mentions that one of their Leeds members, Mick Drury, logged the bleep-bleep from Sputnik No. 1 for three days and sent a detailed report of reception to Moscow at the invitation of a Russian radio magazine. He has now received a colourful acknowledgment card depicting a Sputnik encircling the globe—and the inevitable large Red Star. Incidentally, he also made a tape recording of the bleeps.

recipients, although many amateurs do patiently send cards to listeners who they feel are trying to be helpful despite their lack of usefulness.

Keen "ether" searchers who report intelligently will invariably get a high percentage of verifications, many of them, like the Sputnik card, of considerable interest.

## Fireside Listening

Recently I wrote of matchbox receivers, and some interesting correspondence with readers has ensued. An outstanding application of the idea comes from Mr. O. G. Kerslake who builds miniature receivers into tiny radiograms which form a part of 3-D stage sets which are surrounded by a gilt picture frame for hanging on walls. The

## *Centre Tap* talks about items of general interest

The pastime of short-wave listener QSL collecting has greatly declined in recent years. During the thirties, and even the early post-war years, it was quite a thing. In the early days of short-wave broadcasting many stations were eager for reception reports and gladly acknowledged with a colourful card. Amateur stations, too, were often pleased to have detailed listener reports which they QSL'd conscientiously. Unfortunately a large number of listeners began to send off slap-dash reports to any and every station they heard. This obsession with card collecting (with utterly useless "reports") merely served to exasperate amateurs, and DX broadcasters who knew perfectly well that consistently good reception was possible in that particular area, didn't want reports, let alone the bother of verifying them. As a result listener reporting rather fell into bad favour and even useful and helpful reporters suffered at the lack of response shown by

photograph gives an idea of the finished result.

The scene can be built up with dolls house furniture or specially made pieces in contemporary style. In the scene illustrated the radio really works and can be heard clearly at the far end of the room. The clock which tells the correct time is the dial and movement from a small wrist watch; the mirror forming the overmantel is one of the type used in birdcages. A small glass cat sits beside the fire. The figure sitting in the scene is a cut-out of your wife or girl friend—failing possession of either of these you will have to fall back on a pin-up personality.

The usual plaques or model scenes are dead and of little interest, but here is a working model which might well be based on real life or be an actual scene from your own drawing room, complete with carpet and rug. Other working parts might well be included by imaginative readers. For instance, in the

scene illustrated I would suggest that a "live" fire could be simulated by a peanut bulb behind red celluloid set inside the grate. A small piece of suspended foil would rotate automatically by the heat, giving apparent life and movement to the fire. The purist might even add a little Eureka wire element so heat comes off as well!

The great thing, of course, is to keep everything in the correct proportion to ensure naturalness and reality.

could shave in the mirror while listening for the time-signal and weather report. This column would welcome details (with photograph) of any models made up by readers, especially of the equipment used for the radio.

Mr. Kerslake is willing to supply working models to trade distributors, etc. His address is 18 Wickham Avenue, Bexhill-on-Sea, Sussex.

As a final suggestion for those who have

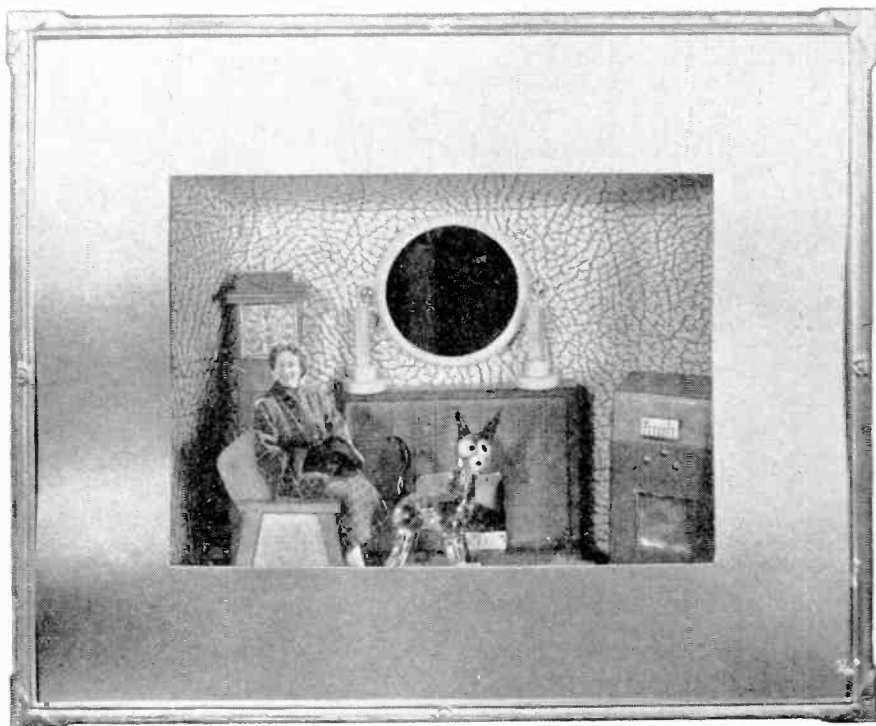

• Reader O. G. Kerslake's Picture Frame Receiver

As far as the radio side is concerned, a moving coil headphone earpiece (or even an old m/c microphone) will serve as the loudspeaker, and with the advent of transistors and deaf-aid components a set which would really fit into the "radiogram" cabinet might well be designed. Alternatively, a little judicious cheating is permissible with the larger components hidden behind the breast of the fireplace or even at the back of the scene. There is still time to get one ready as a Christmas present for a special friend. A small ceiling light could be fitted. Thus one

no particular scene in mind, why not build up a miniature broadcast studio scene with the sound coming from one of the monitor loudspeakers?

#### Variety

Of the many readers who wrote on the type of articles they like in *R.C.* and its general policy, all praised its wide range of subjects and many say they would like to see an even wider field. A South Australian reader, Mr. E. M. P. Wells of 59 Scottish Avenue, Clovelly Park, suggests we might

emulate the Australian *Radio and Hobbies* magazine. For British readers unfamiliar with this magazine, I might mention that up to half its contents are given over to articles of scientific interest. Occasionally such subjects as astronomy are covered, but in these days of radio-equipped sputniks perhaps the latter is not really so remote from our hobby after all.

He would like to hear of readers' experiences on the efficient frequency range of transistors and also their employment in hi-fidelity circuits. He does not like ultra-miniaturisation (matchbox sets, etc.) but readily appreciates that other readers do. One of the chief reasons for his interest in transistors is on account of the exorbitant cost of batteries "down under." Readers who do see copies of Australian magazines are invariably horrified at the prices of all radio gear, many items costing more than double the list price in U.K. and then gaily advertised as bargains. If you are thinking of emigrating to Australia, take as much gear as you can carry.

He also asks about projection t.v. Am afraid, OM, interest over here has largely languished chiefly on account of cost, and with many others I personally feel that the "eventual" t.v. receiver will be in the form of a flat picture to be hung on the wall or stood on the mantelshelf.

#### Reely!

To get round to other correspondents. From P.M. (Gainsborough) comes a complaint. He writes: "Recently you said you were open to receive readers' criticisms. Here is one, and an important one, I think. Insist that all set designers stick to coils of well-known and easily obtainable makes. This business of so many turns of 32 s.w.g. enamelled on a  $\frac{1}{2}$ in former is both irritating and expensive. It is almost impossible nowadays to buy either the wire or a former without a lot of trouble. In any case you have to buy far more wire than you need and the rest of it is usually waste. Even if the gauge happens to be right for the next winding job, the specification is sure to call for either silk or cotton-covered. Because of this silly practice I have already collected half-a-dozen reels which, as far as I can foresee, are useless. In any case the ready-made coils are cheaper than buying the wire. Otherwise the magazine is all right but more articles on refinements such as magic eyes, tuning meters, remote control, noise suppression, etc. would further improve it."

#### In Brief

Further opinions on the question of club gramophone records serve to confirm those summarised last month. I gratefully acknowledge views and opinions from E.J.N. (Clayton, Newcastle, Staffs.), D.L.A. (Essex Road, Gravesend), E.A.S. (Branksome Park, Bournemouth), R.A.N. (Sidcup), T.H.S. (Slough) and regret my inability to reply to them in detail.

My recent comments on that happy outcome of our hobby, a very real international fraternal spirit, brings further news from our good friend, G. A. Partridge (G3CED) of the widening activities and world-wide expansion of the International Ham Hop Club of which he is the hon. secretary. Through the medium of the club many pleasant individual international friendships have been formed, mutual holidays planned and exchange hospitality arranged.

A more recent introduction is the Friendship Link which is now in operation to enable local clubs to form a link with a similar club overseas. Group membership of the H.H.C. is not essential. I know that the ideas both of individual and club schemes will commend themselves to home and overseas readers, and would remind those interested that G3CED's address is 17 Ethel Road, Broadstairs, Kent. He will be pleased to supply full details.

#### What's My Line?

A.G. of Ewell asks, in a cheery letter: "I have often been amused by some of the sub-headings you use. They remind me of the sub-titles used for the small news items on the front page of the London *Evening News*. You wouldn't happen to be the same chap, would you?" The answer, I am afraid, is no, but on A.G.'s recommendation I am considering applying for the job when it falls vacant.

Finally R.M., of Dorking, another of the Old Timer school, writes: "How thankful I am that I kept up my interest in the technical side of radio. The t.v. programmes are so dull (except for sport and outside broadcasts) that I should be bored to death if I couldn't get some fun out of constructing, adjusting and experimenting, which is more than most licence-holders get. As for the plays—most of them are feeble, especially those written 'specially for t.v.'—a phrase I've learned to dread. Produced for any form of entertainment for which an admission fee is charged, the customers would want their money back—and if they didn't get it they would be justified in wrecking the theatre."

---

## Radio **HOBBIES** Exhibition

We shall be pleased to see you at Stand 29

---

# FM

# facilitated

BY A. S. CARPENTER

*A suitable and economically-made amplifier for use with a modified RF27 unit*

THE V.H.F. SERVICE DOES MAKE QUALITY listening possible—provided well-set-up apparatus is used at the receiving end—and many and varied are the tuners available either ready made or in kit form. FM equipment must, however, comprise something more than merely a tuner, and the overall expense entailed is not negligible.

To the unwealthy would-be listener the RF27 unit can be highly recommended as a "front end," only small modifications being required; and as the unit is a powerful one it is well suited to use in fringe areas. An article giving the necessary alterations appeared in an earlier issue of this journal<sup>1</sup>, but although no actual details were given regarding the i.f. strip this may well conform to a standard design and, provided B7G-based valves and miniature i.f. transformers are used, ample erection space exists on the side

flange of the unit. A suitable i.f. strip is illustrated in Fig. 4 (which has been approved by Denco (Clacton) Ltd.) and no problems should arise regarding its construction. It is interesting to learn that the ratio discriminator transformer specified is now obtainable in a can 1¼ in. square as opposed to the original size of 1½ in. FM alignment has been adequately dealt with in previous issues<sup>2</sup> and will not be repeated here.

When this has been done—and provided some means of powering the apparatus has been found—one may then feed the output into the gram. sockets of a broadcast receiver, but as this is not always convenient, or desirable, some other method must be adopted.

Unfortunately, not everyone can afford a push-pull amplifier; and assuming that none such is available—or likely to be due to the

<sup>1</sup> "The Radio Constructor", January 1957.

<sup>2</sup> "The Radio Constructor", June 1955; August 1956.

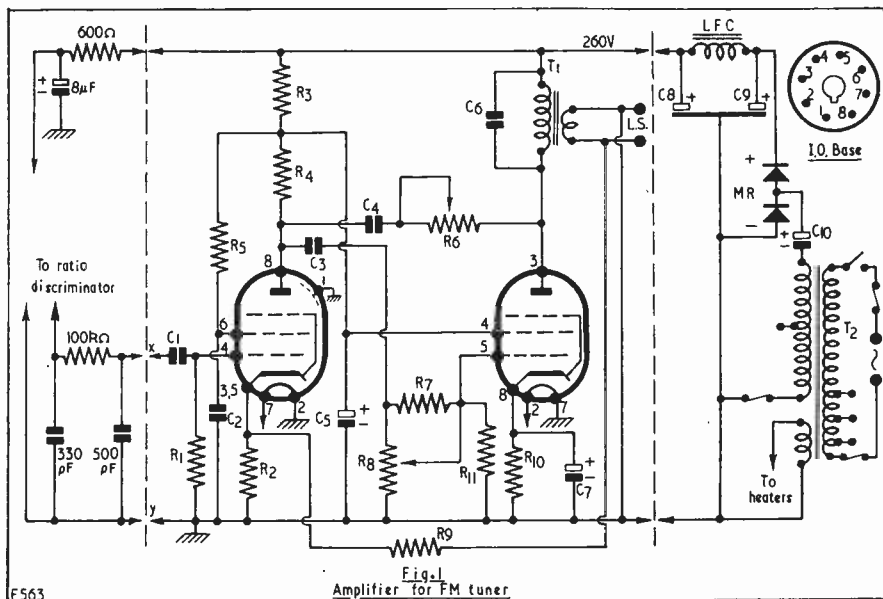

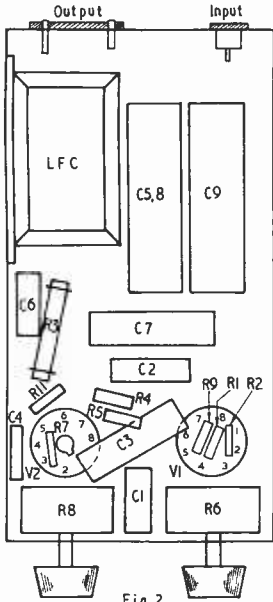

Fig. 2  
Amplifier layout below chassis

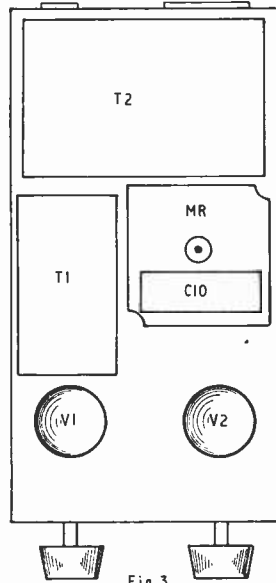

Fig. 3  
Amplifier layout above chassis

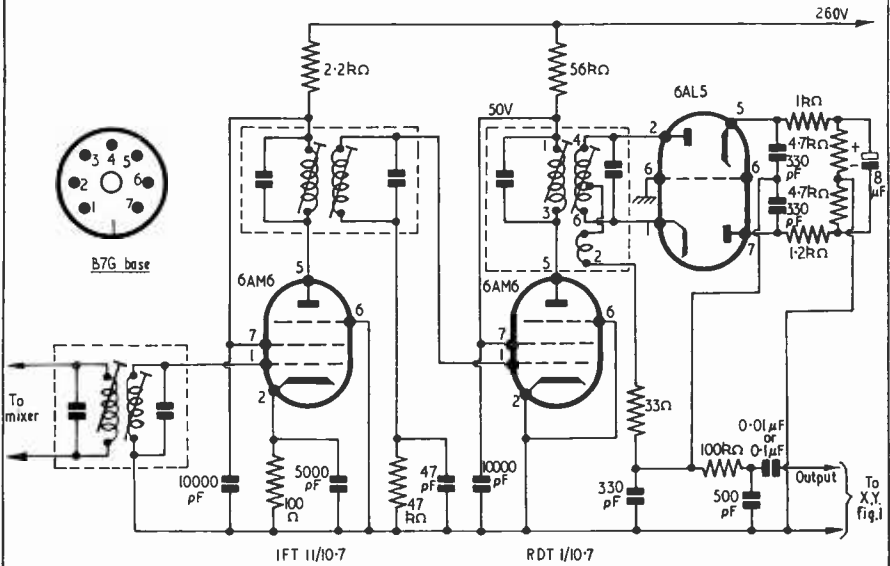

Fig. 4  
A suitable LF/discriminator strip for use with the equipment.



expense already entailed—one could do worse than use something like that depicted in Fig. 1, which, please note, will stand most conveniently beside the RF unit due to both chassis being the same size—or the two may be bolted together and panelled.

The output from this comparatively inexpensive amplifier is considerably more than that generally required—even when the tone control is turned full travel—and sufficient space exists on the same chassis for a power supply so that the whole equipment becomes compact and self-contained. Quality is excellent, and will be found superior to that obtainable from the average domestic receiver.

The amplifier proper—contained between the two vertical broken lines in the diagram—has its actual input points marked “X” and “Y”; but the preceding de-emphasis network is shown as component values are chosen to permit the amount of “top” required. It has also been found beneficial, in this case, to place the volume control in the grid circuit of  $V_2$ . Since a small, self-contained speaker is inadequate, provision is made for an external unit, that used by the author being a 10in model, baffle mounted.

The power supply section is shown merely for interest since a voltage multiplying circuit is used in conjunction with a centre tapped rectifier and a surplus mains transformer that failed to supply sufficient “push” in any other way except auto-connected; as the latter method meant a live chassis the idea was discarded. As it stands, 290 volts are available at  $C_9$ , of which 30 volts are dropped across the choke leaving sufficient to maintain the current of 100mA demanded by the complete equipment. Anyone wishing to duplicate the supply arrangements should ensure that the mains transformer secondary can cope without overheating, and adequate fuses should be incorporated. The value of  $C_{10}$  (which must not be a canned type) should be chosen in relation to that of  $C_9$  and although complete doubling is not possible with this configuration, the voltage made available does tend to increase as the value of  $C_{10}$  approaches that of  $C_9$ .

Component values specified for the amplifier section should be closely adhered to, and provided the h.t. rail is maintained at the voltage shown the overall response will be found remarkably good, low distortion resulting from the use of proportioned negative feedback.

Layout diagrams for the amplifier are illustrated in Figs. 2 and 3.

#### List of Components for the Amplifier

(Component values for the i.f. strip are shown in Fig. 4).

##### Capacitors

$C_{1, 2, 3}$	0.1 $\mu$ F
$C_{4, 6}$	2,000pF
$C_{5, 8}$	12 + 12 $\mu$ F electrolytic 500V
$C_7$	50 $\mu$ F electrolytic 50V
$C_9$	32 $\mu$ F electrolytic 500V
$C_{10}$	8 $\mu$ F electrolytic 500V

##### Resistors

$R_1$	4.7M $\Omega$
$R_2$	100 $\Omega$
$R_3$	4.7k $\Omega$ , 1 watt
$R_4$	100k $\Omega$
$R_5$	470k $\Omega$
$R_6$	2M $\Omega$ pot
$R_7$	10k $\Omega$
$R_8$	2M $\Omega$ pot with switch
$R_9$	4.7k $\Omega$
$R_{10}$	470 $\Omega$ , 1 watt

##### Transformers

$T_1$	Output transformer to match 6V6 to required speech coil.
$T_2$	See text, or input: 230V; output: 275–0–275V at 100mA, 6.3V at 3 amps

M.R.—See text, or 6X5 valve rectifier

##### Valves

$V_1$	6SH7
$V_2$	6V6

##### Miscellaneous

LFC	—Miniature choke: 10 henry, 100mA
I.O. valve bases	(2)
Coaxial plug and socket,	Belling-Lee
Control knobs	(2)
Fuses, wire, nuts, screws, etc.	
Chassis	—8in x 4½in x 1½in

To Be Published Mid-November . . .

# The RADIO AMATEUR OPERATOR'S HANDBOOK

REVISED EDITION 1958—1959

Now includes Prefixes/Directional Bearings table in addition to the usual popular features

*Essential to keep your shack up to date - 3s. 6d. postage 4d.*

NOVEMBER 1958

279

*The* **MULLARD**  
**TAPE**  
**AMPLIFIER**  
**“Type C”**

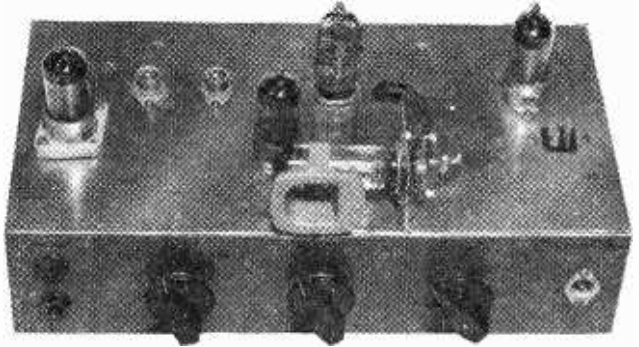

PART 1

Described by R. H. WEBB

THERE IS NO DOUBT THAT THERE IS CONSIDERABLE attraction in being able to make one's own recordings of events, whether they be personal ones or those of general public interest. The tape recorder with its associated recording and play-back amplifier makes it possible for the home constructor, with a moderate amount of knowledge and skill, to take advantage of this particular form of entertainment which can be used for simple pleasure purposes or for more serious occasions. Amateur cine operators have a use for a tape recorder for adding their own comments to home movies. Again, radio broadcasts can be transcribed into a tape recording and replayed indefinitely, whilst the possibilities of borrowing good records for an evening in order to make your own permanent recording for future replaying must not be overlooked. For business use, of course, the usefulness of the tape recorder is only too well known, use being made of the fact that messages and instructions can be left "on tap" for action to be taken in the principal's absence. A very good range of pre-recorded tapes can also be obtained covering a field which will adequately cover the needs of high and low brow alike.

Considering the above and many other uses of a tape recorder, it will be realised that certain of these functions can best be catered for by specially designed equipment. For example, for the sake of portability one would

be prepared to accept a few less features such as lower output and, to a certain extent, quality of reproduction. In this connection it is only fair to state that some portable recorders achieve a sufficiently high standard of reproduction to satisfy most listeners, but there is always a case for getting the very best out of the recording, and it is here that a combination of high quality tape pre-amplifier and main amplifier can be used to obtain a really full frequency range of reproduction. Before embarking on a programme of building equipment, consider first the prime requirement, which is to be sure that the loudspeaker you use is capable of satisfactorily reproducing the full range of frequencies that the amplifier and recording apparatus pass to it. At the upper frequencies you may be content if the speaker manufacturers quote a limit of 16,000 cycles per sec. which will ensure that your keenest listeners will hear the 14,000 c/s you might expect them to claim as being their upper limit. At the lower end be satisfied with 40 cycles per sec. otherwise you will find yourself spending considerable time trying to eliminate various very low frequency noises between 20 and 40 c/s. which need not bother you when seeking normally good full frequency reproduction.

For such a "hi-fi" recorder and amplifier as that about to be described, a further requirement is a good high quality main amplifier, and the amplifier for which the

"Type C" was intended is the well-known Mullard "5-10," although other main amplifiers may be used provided they are accepted as reproducing the correct degree of high quality.

Power supplies for the main amplifier are, for the purposes of this article, taken as being available whilst supplies for our tape pre-amplifier will be described as a separate unit, a note being included regarding the requirements of certain tape decks.

to the existing gramophone pick-up and/or radio input sockets. A standard "5-10" with single input facilities only can most conveniently be converted for general use by re-building the front end to incorporate the "Versatile 2-Valve Audio Pre-Amplifier" described in the March 1958 *Radio Constructor*, and which is now obtainable as a booklet, reference RR7 (price 1s., postage 2d.) from the publishers of this journal. Various other forms of pre-amp. for the "5-10" are avail-

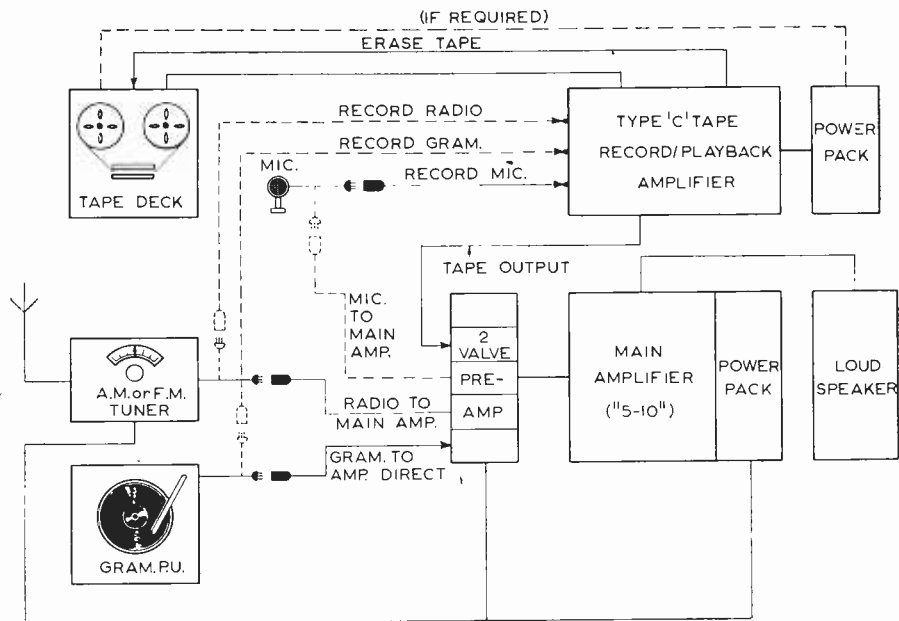

FIG. 1

Block schematic diagram of all facilities available with equipment described. (Note: Dotted lines indicate alternative connections.)

Various tape decks will be mentioned, there being no particular preference indicated, the choice being left entirely to the reader to suit his pocket and his own equipment housing requirements. This should present little individual difficulty as the specification of the "Type C" amplifier includes all the necessary switching arrangements in respect of tape speed and the accompanying equalisation.

On the assumption that the reader already possesses a main amplifier in the form of a Mullard "5-10," provision for a tape input is required on the main amplifier in addition

able, some of which include a "Tape" input position and most of which would be suitable to link the facilities shown in the block schematic diagram, Fig. 1.

A 3-valve pre-amp. will be described later which embodies a "Programme Recording Outlet" in addition to the normal pre-amp. output socket. This will enable the input signal which is being recorded to be fed into the appropriate pre-amp. channel and then via the "Programme Recording Outlet" on the pre-amp. to the tape amplifier input circuit, thereby providing a monitoring facility which is very often desirable if only

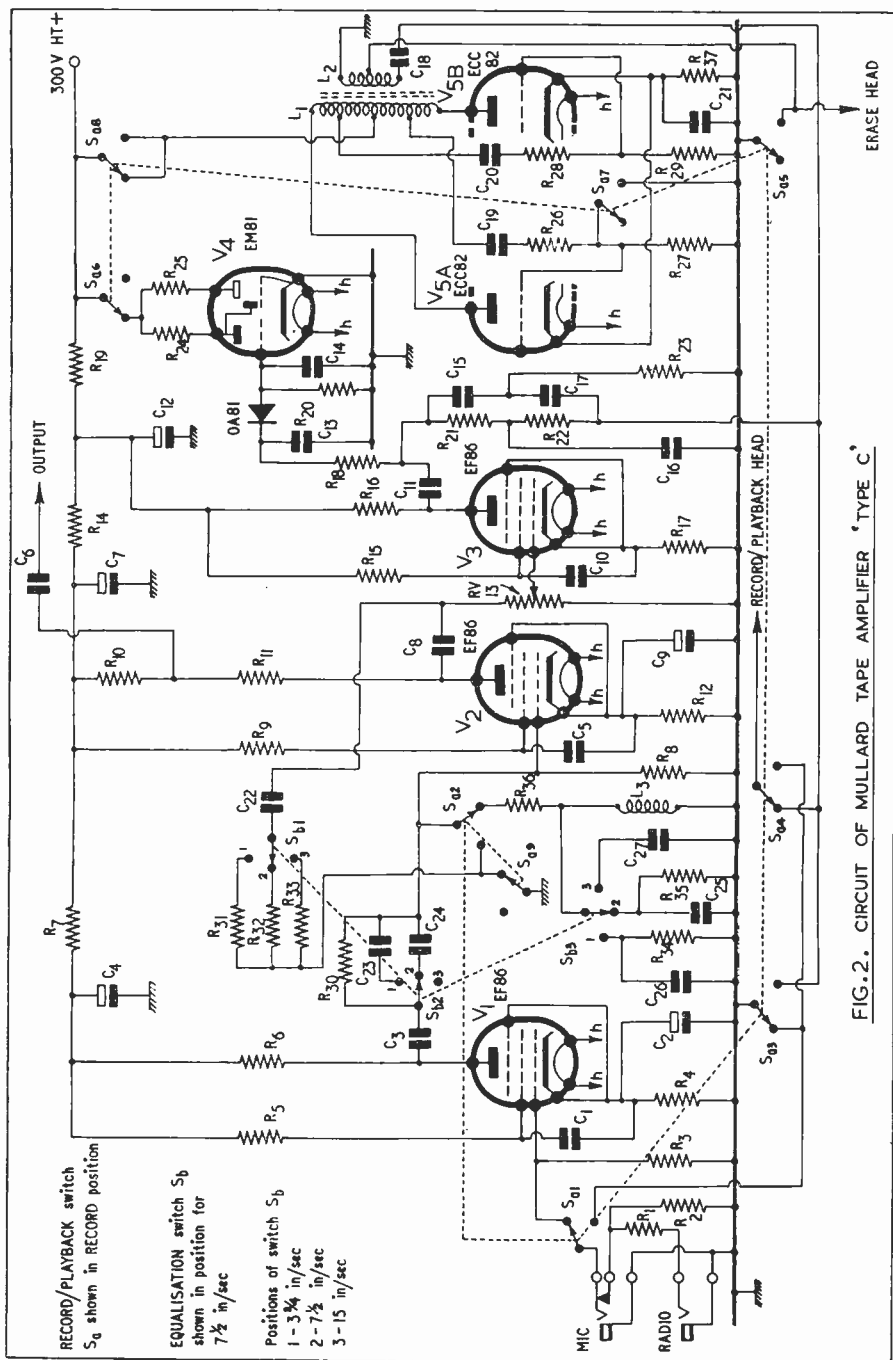

FIG. 2. CIRCUIT OF MULLARD TAPE AMPLIFIER 'TYPE C'

List of Component Values for Type C Amplifier

Resistors

- R<sub>1</sub> 680kΩ ± 10% 1W
- R<sub>2</sub> 5.6kΩ ± 10% 1W
- R<sub>3</sub> 2.2MΩ ± 10% 1W
- R<sub>4</sub> 2.2kΩ ± 5% 1W
- R<sub>5</sub> 1MΩ ± 5% 1W
- R<sub>6</sub> 220kΩ ± 5% 1W
- R<sub>7</sub> 33kΩ ± 10% 1W
- R<sub>8</sub> 1MΩ ± 10% 1W
- R<sub>9</sub> 390kΩ ± 10% 1W
- R<sub>10</sub> 18kΩ ± 10% 1W
- R<sub>11</sub> 82kΩ ± 10% 1W
- R<sub>12</sub> 1kΩ ± 10% 1W
- R<sub>13</sub> 500kΩ logarithmic 10% law; carbon potentiometer
- R<sub>14</sub> 27kΩ ± 10% 1W
- R<sub>15</sub> 220kΩ ± 10% 1W
- R<sub>16</sub> 68kΩ ± 10% 1W
- R<sub>17</sub> 1kΩ ± 10% 1W
- R<sub>18</sub> 470kΩ ± 10% 1W
- R<sub>19</sub> 10kΩ ± 10% 1W
- R<sub>20</sub> 1MΩ ± 10% 1W
- R<sub>21</sub> 56kΩ ± 10% 1W
- R<sub>22</sub> 56kΩ ± 10% 1W
- R<sub>23</sub> 27kΩ ± 10% 1W
- R<sub>24</sub> 560kΩ ± 10% 1W
- R<sub>25</sub> 150kΩ ± 10% 1W
- R<sub>26</sub> 4.7kΩ ± 10% 1W
- R<sub>27</sub> 22kΩ ± 10% 1W
- R<sub>28</sub> 4.7kΩ ± 10% 1W
- R<sub>29</sub> 22kΩ ± 10% 1W
- R<sub>30</sub> 390kΩ ± 10% 1W
- R<sub>31</sub> 2.7MΩ ± 10% 1W
- R<sub>32</sub> 1.2MΩ ± 10% 1W
- R<sub>33</sub> 680kΩ ± 10% 1W

1 High stability.

2 Values may be adjusted to vary output impedance.

- R<sub>34</sub> 150kΩ ± 10% 1W
- R<sub>35</sub> 470kΩ ± 10% 1W
- R<sub>36</sub> 27kΩ ± 10% 1W
- R<sub>37</sub> 680Ω ± 10% 1W

Capacitors

- C<sub>1</sub> 0.5μF, paper, 350V
- C<sub>2</sub> 50μF, electrolytic, 12V
- C<sub>3</sub> 0.1μF, paper, 350V
- C<sub>4</sub> 8μF, electrolytic, 350V
- C<sub>5</sub> 0.1μF, paper, 350V
- C<sub>6</sub> 0.1μF, paper, 350V
- C<sub>7</sub> 8μF, electrolytic, 350V
- C<sub>8</sub> 0.1μF, paper, 350V
- C<sub>9</sub> 50μF, electrolytic, 12V
- C<sub>10</sub> 0.5μF, paper, 350V
- C<sub>11</sub> 0.1μF, paper, 350V
- C<sub>12</sub> 16μF, electrolytic, 350V
- C<sub>13</sub> 18pF, silvered mica
- C<sub>14</sub> 0.05μF, paper, 150V (Min.)
- C<sub>15</sub> 47pF, silvered mica
- C<sub>16</sub> 100pF, silvered mica
- C<sub>17</sub> 47pF, silvered mica
- C<sub>18</sub> 56pF, silvered mica, 350V
- C<sub>19</sub> 0.005μF, paper, 350V
- C<sub>20</sub> 0.005μF, paper, 350V
- C<sub>21</sub> 0.1μF, paper
- C<sub>22</sub> 82pF, silvered mica
- C<sub>23</sub> 180pF, silvered mica
- C<sub>24</sub> 82pF, silvered mica
- C<sub>25</sub> 390pF, silvered mica
- C<sub>26</sub> 2,200pF, silvered mica
- C<sub>27</sub> 100pF, silvered mica

Inductor

- L<sub>3</sub> Mullard Ferroxcube wound pot core type WF816

Oscillator Coil

- L<sub>1</sub>, L<sub>2</sub> Mullard Type WF1388

Valves and Germanium Diode

- V<sub>1</sub> Low noise pentode, Mullard type EF86
- V<sub>2</sub> Low noise pentode, Mullard type EF86
- V<sub>3</sub> Low-noise pentode, Mullard type EF86
- V<sub>4</sub> Tuning indicator, Mullard type EM81
- V<sub>5</sub> Output triode, Mullard type ECC82
- MR Germanium diode, Mullard type OA81

Miscellaneous

- Recessed coaxial output socket. Belling Lee L/734/S
- Record/playback head coaxial socket. Belling Lee L/604/S
- Erase head coaxial socket. Belling Lee L/604/S
- Supply input socket. Eicom PO4
- Input jack (radio). Igramic P71
- Input jack (microphone). Igramic P72
- B9A valveholder (two). McMurdo BM9/U
- B9A nylon-loaded valveholder with screening skirt (two). McMurdo XM9/UC1, skirt 811
- B9A nylon-loaded valveholder with screening skirt and flexible mounting. McMurdo XM9/UG1
- Record/playback switch SA
- Shirley Laboratories Ltd., 16370/B3
- Specialist Switches, SS/567/A
- Equaliser switch SB, 3-pole, 3-way
- Specialist Switches, SS/567/D
- Five-way tagboard (one). Bulgin C120
- Ten-way tagboard (three). Bulgin C125
- Ceramic stand-off insulator (three). Must be capable of withstanding 350V

for editing purposes. In this event the main amplifier is utilised with the input to it at recording level.

The tape amplifier about to be described first appeared in the Mullard booklet "Circuits for Tape Recorders" (issued in 1956), and was called the "Type B" amplifier. A second version appeared in August 1957 called the "Type C," and whereas treble equalisation in the "Type B" was obtained by twin-T networks in the negative feedback loop using a series of plug-in units for the components, the "Type C" uses a passive attenuator comprising a non-adjustable Ferroxcube pot core inductor in a resonant circuit, adjustment for different tape speeds being effected by switching in the values of capacitance in the resonant circuit. The greater flexibility of the treble boost in the "Type C" amplifier allows better control of the complete frequency response and the reproduction of slightly higher frequencies. An EL84 valve was used as an H.F. oscillator to provide bias and erase current in both the "Type B" and first "Type C" amplifiers. In the present version, here described, this function is performed by an ECC82 double triode, the new circuit being arranged to work in push-pull using a Ferroxcube cored oscillator transformer which it is intended shall be universally suitable for a number of tape deck playing and recording heads.

### Description

The tape recording amplifier here described is intended to be used in conjunction with a high-quality pre-amplifier and power amplifier. The unit combines the function of both recording and playback amplification, although, in the playback operation, it acts only as an equalising stage, giving sufficient output to drive the high-quality system.

The general principle of the design has been to preserve simplicity as far as is compatible with high-quality performance. The distortion introduced in the recording channel has been reduced to such an extent that it is probable that the quality of performance will be limited only by the magnetic tape itself, provided, of course, that the tape deck used is of satisfactory performance. The level of total harmonic distortion in the recording process should not be greater than 0.5% with a recording current of 150 $\mu$ A through the head.

Equalisation to correct for head and tape characteristics is provided for each of the tape speeds: 3 $\frac{3}{4}$ , 7 $\frac{1}{2}$ , and 15 inches per second. The high-frequency equalisation is applied during the recording process and the low-frequency during playback.

Treble equalisation is achieved by using a Ferroxcube pot core inductor in a resonant circuit between the first and second stages of

the amplifier. The frequency at which maximum treble boost occurs is determined by the tuning capacitance which can be adjusted by the switch SB<sub>3</sub>. The value of resistance in the feedback network to give bass equalisation during playback is selected for each tape speed by the switch SB<sub>1</sub>.

There is no provision for tone control in the Type C amplifier. It is anticipated that such control will be available with the associated amplifier.

## PERFORMANCE CHARACTERISTICS

### Frequency Response

The overall response of the recorder depends on the type of head used, the magnitude of the bias current, and, to some extent, on the tape employed. The low-frequency response depends on the amplifier used rather than on the type of head, and in this design, it will not be more than 3dB down at 50 c/s. The high-frequency response depends on the tape speed and the gap width of the head. With heads having a gap width of 0.005in, the following performance can be obtained:

15in/sec	$\pm 3$ dB (relative to the level at 1 kc/s) from 50 c/s to 17 kc/s
7 $\frac{1}{2}$ in/sec	$\pm 3$ dB (relative to the level at 1 kc/s) from 50 c/s to 12 kc/s
3 $\frac{3}{4}$ in/sec	$\pm 3$ dB (relative to the level at 1 kc/s) from 50 c/s to 5 kc/s

Greater flexibility is achieved in the treble boost circuits of the Type C amplifier compared with those of the original Type B unit. Consequently, better control of the complete response of the amplifier is possible, and equalisation to slightly higher frequencies is practicable. However, these improvements depend on the individual adjustment of component values to suit the head and tape being used. The component values given in this article apply only to the amplifier when it is used with E.M.I. recording tape and a Collaro tape transcriptor.

Ferroxcube pot cores are adequately screened to prevent excessive hum or stray bias being picked up, and they do not appear to cause more circuit-ringing than R-C networks which will produce the same treble boost.

The playback characteristic of the amplifier conforms to the specification of the International Radio Consultative Committee (C.I.R.), thus permitting excellent reproduction of pre-recorded tapes. The recording characteristic is arranged to give a flat frequency response in conjunction with this playback characteristic. Additional head losses occurring during playback will normally be capable of correction by the tone controls situated in the associated amplifying systems.

## Sensitivity

The sensitivity of the recording process is measured with the control RV<sub>13</sub> set for maximum gain. This, of course, does not apply to the playback sensitivity because the gain control is not operative at the point from which the output is taken for the associated equipment.

### Recording Sensitivity

(measured at 1 kc/s, with recording-head audio current of 150 $\mu$ A)

- (a) Microphone input: 0.5mV for peak (impedance=2M $\Omega$ ) recording level
- (b) Radio input: 65mV for peak (impedance=700k $\Omega$ ) recording level

### Playback Sensitivity

(measured at 5 kc/s for each tape speed for output of 300mV)

- (a) 15 in/sec: 5.5mV
- (b) 7 $\frac{1}{2}$  in/sec: 2.4mV
- (c) 3 $\frac{3}{4}$  in/sec: 1.0mV

## CIRCUIT DESCRIPTION

The circuit diagram of the combined record/playback amplifier is given in Fig. 2. The record/playback switch SA is shown in the "record" position and the equaliser switch SB is in the position for equalisation at a tape speed of 7 $\frac{1}{2}$  inches per second. The output during playback is taken from the anode of the second EF86, and the remaining stages are used only for the recording operation.

## Controls

Two switch banks are used in the amplifier. Switch SA provides the change from the recording to the playback process, and switch SB provides equalisation appropriate to one of the tape speeds: 3 $\frac{3}{4}$ , 7 $\frac{1}{2}$  and 15 inches per second.

The gain control RV<sub>13</sub> is the only other control in the amplifier.

## Valve Complement

The complete amplifier uses five Mullard valves and one Mullard germanium diode. These are:

- (a) Type EF86, low noise pentode, used in the input stage.
- (b) Type EF86, used in the second stage.
- (c) Type EF86, used in the output stage for recording.
- (d) Type ECC82 (double triode), used as an oscillator for the bias and erase currents.
- (e) Type EM81, tuning indicator, used in the recording level stage.
- (f) Type OA81 germanium diode, used as the indicator-circuit rectifier.

## Input Stage

The pentode, type EF86, acts as a voltage amplifier for both recording and playback

processes. It is possible to record from either microphone or radio sources, the radio input also being convenient for recording from crystal pick-ups. Both inputs are fed to the grid of the valve, the radio input being attenuated to the level of the microphone input. The switching is achieved by inserting the jacks: thus only one input may be used at a time.

## Equaliser Stage

As was stated above, no tone control is incorporated in this stage. The output is taken during playback from across part (R<sub>10</sub>) of the anode load of the EF86. The output supplied is 300mV at a source impedance of 20k $\Omega$ . A rearrangement of the anode load resistance (that is, R<sub>10</sub> and R<sub>11</sub>) can be made, if required, to give an output of, for instance, 1V at a source impedance of 60k $\Omega$ .

The output of the second stage of the amplifier is fed during the recording process from the anode of the EF86 by way of the gain control of RV<sub>13</sub> to the grid of the following EF86.

As previously explained, a resonant circuit containing a Ferroxcube pot core inductor L<sub>3</sub> is used to provide treble equalisation. The value of tuning capacitance in the resonant circuit is selected by the switch SB<sub>3</sub> to give the maximum treble boost at frequencies appropriate to the tape speed used. The extent of treble boost is controlled by the resistor R<sub>30</sub> and the damping resistors R<sub>34</sub> and R<sub>35</sub> connected in parallel with the capacitors C<sub>26</sub> and C<sub>25</sub>. The steep rise in boost which occurs below the resonant frequency is modified by damping the inductance, and by partially shunting the resistor R<sub>30</sub> at the appropriate frequency.

The values of the resistors R<sub>31</sub>, R<sub>32</sub> and R<sub>33</sub> arranged on switch SB<sub>1</sub> have been chosen to give appropriate feedback for bass equalisation during playback.

## Recording Output Stage

The third stage of the unit, operative only during the recording process, uses another EF86, the grid of which is fed from the gain control RV<sub>13</sub>. The stage is designed to give low harmonic distortion at peak levels of recording current, and the distortion should not exceed 0.5% for a recording current of 150 $\mu$ A.

The recording current is fed to the recording head by way of a parallel-T network, which acts primarily as a bias-voltage rejector circuit. The series resistance of the network is needed in this stage to ensure a constant current drive to the head, and its inclusion is also desirable to preserve a satisfactory a.c./d.c. load ratio for the EF86 of the third stage. *continued on page 297*

## AUDIO

### The Cooper-Smith

# PRODIGY

6-watt

high

fidelity

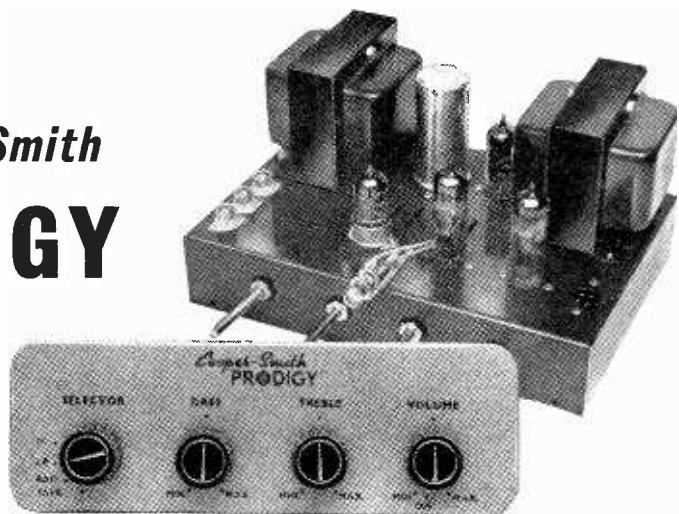

## AMPLIFIER

PART 2

Described by J. COOPER

### Construction

Building the amplifier should be done in stages as detailed below. Although this makes the drawings very easy to follow, experience shows that most failures are due to errors and omissions in wiring, and it is strongly recommended that the point-to-point checks be used as each stage is completed.

For soldering use a small iron and resin-cored solder. Do *not* use liquid flux such as Baker's Fluid. After soldering each joint, give the wire a tug to ensure that a proper electrical connection has been made.

Where several wires are taken to the same solder tag, it is usually advisable to delay the actual soldering until they are all in position rather than to solder each wire separately. Make sure, however, that all the wires *are* soldered. Keep all wires and components clear of each other.

**Stage 1.**—Mount all components shown on drawing, starting with  $T_1$  and  $T_2$ .

**NOTE.**—All valveholders must be fitted with the blank position towards the left of the chassis (marked L on drawing).  $V_1$  is fitted on top of the chassis, the others underneath. Do not pull tags out of alignment (a good idea is to insert an old valve while wiring). It is advisable to solder about an inch of the 16 gauge wire

provided for the busbar to the spigot of each holder before fitting. The busbar can then be soldered to the ends of these when wiring up.

Position the transformers in relation to the colours of the leads. Use long screws where shown when fitting. Fit solder (earthing) tag on  $T_2$  and radio input socket retaining screws where indicated.

Smoothing Capacitor (50–50 $\mu$ F) fixing plate should be underneath chassis. The red dot must be nearest right of chassis. Twist lugs to secure.

The Voltage Selector panel should have the larger solder tags furthest from top of chassis.

Bend tag 1 of fuse holder at 90°.

When fitting potentiometers allow only just sufficient thread to protrude through chassis so as to provide maximum clearance between potentiometers and chassis. \*Only the two solder tags shown on the drawing on  $S_3$  are used. (VR<sub>3</sub>).

The output socket should be fitted so that the wider spaced pins are nearest to the top of chassis.

Wire up as shown, using sleeving where indicated. Make sure that all enamel is removed from transformer leads and that each wire is properly



L

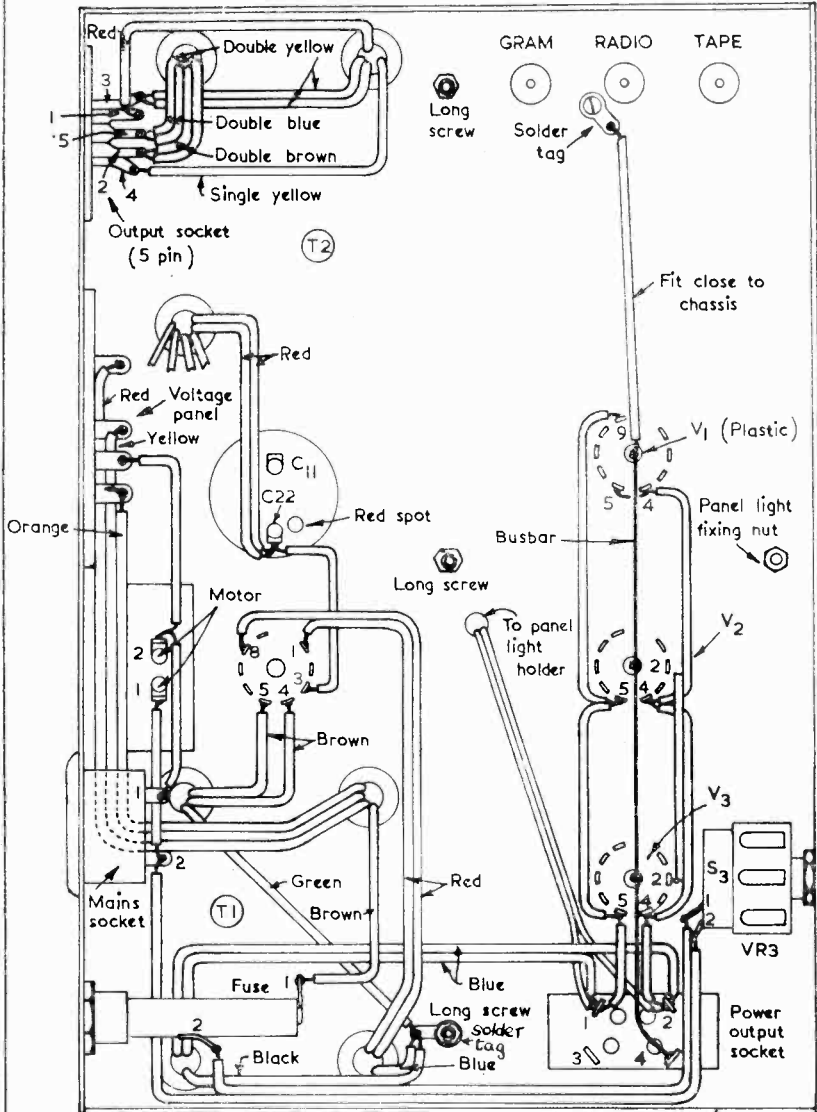

R

WIRING - STAGE ONE

G493

tinned. Leads are shown parallel in the drawing for the sake of clarity but they may, of course, be twisted together if desired.

Input sockets. Care must be taken that the iron is not left too long on these components, as this will soften the plastic. (Insert plug before soldering.)

Green lead (electrostatic shield)—solder (earth) tag.

T<sub>1</sub> Secondary:

Twin brown leads—4 and 5 on V<sub>4</sub>

Twin red leads—1 and 8 on V<sub>4</sub>

Black lead—solder tag

Blue lead—solder tag

Twin blue leads—1 and 2 on power output socket.

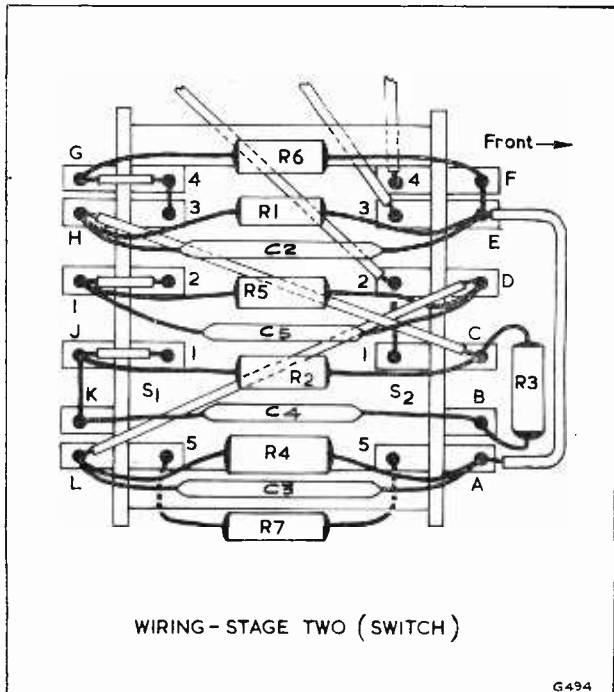

WIRING—STAGE TWO (SWITCH)

G494

POINT-TO-POINT CHECK

Stage 1

T<sub>2</sub> Secondary:

Double yellow lead—3 on output socket (wide spacing, L)

Single yellow lead—4 on output socket (wide spacing, R)

Red lead—1 on output socket (narrow spacing, L)

Double brown lead—2 on output socket (narrow spacing R)

Double blue lead—5 on output socket (centre)

T<sub>2</sub> Primary:

Twin red leads—C<sub>22</sub> (red spot)

T<sub>1</sub> Primary:

Red lead—240V on selector panel

Yellow lead—220V on selector panel

Orange lead—200V on selector panel

Brown lead—1 on fuse holder

Stage 2.—Wire up the selector switch, including wires to input sockets.

NOTE.—Only the inner tags are part of the switch, the outer ones being merely anchor points for the components.

POINT-TO-POINT CHECK

Stage 2

3-4 on S<sub>1</sub>—G

2 on S<sub>1</sub>—I

1 on S<sub>1</sub>—J—K

H—C

L—D

F—E—A

1—2 on S<sub>2</sub>

5 on S<sub>1</sub>—R<sub>7</sub>—5 on S<sub>2</sub>

L—C<sub>3</sub> and R<sub>4</sub>—A

K—C<sub>4</sub>—B

J—R<sub>2</sub>—C

I—C<sub>5</sub> and R<sub>5</sub>—D

H—C<sub>2</sub> and R<sub>1</sub>—E

Valveholders:

9 on V<sub>1</sub>—5 on V<sub>2</sub> and V<sub>3</sub>  
—1 on power output socket

4 and 5 on V<sub>1</sub>—4 on V<sub>2</sub>  
and V<sub>3</sub>—2 on power output socket

3 on V<sub>4</sub>—C<sub>22</sub>

Mains input:

1 on mains socket—1 on motor socket

2 on mains socket—2 on motor socket

1 on mains socket—2 on S<sub>3</sub>

2 on motor socket—Common on selector panel

2 on fuse holder—1 on S<sub>3</sub>

Solder tag on RADIO input socket—spigots on V<sub>1</sub>, V<sub>2</sub>, V<sub>3</sub>—4 on power output socket

Twin flex from 1 and 2 on power output socket—Panel lamp holder.

G—R<sub>6</sub>—F

C—R<sub>3</sub>—B

**Stage 3.**—Mount the rest of the components.

**NOTE.**—The solder tags on the selector switch are nearest the chassis and care must be taken that these do not touch the latter.

Wire up as shown. Make the connection from pin 7 on V<sub>1</sub> first, taking it close to the chassis then up to tag 5 on S<sub>1</sub>. Next in order should be all capacitors.

#### POINT-TO-POINT CHECK

##### Stage 3

2 on S<sub>2</sub>—GRAM

3 on S<sub>2</sub>—RADIO

4 on S<sub>2</sub>—TAPE

5 on S<sub>1</sub>—7 on V<sub>1</sub>

A on selector switch—C<sub>9</sub>—3 on VR<sub>1</sub>

A on selector switch—R<sub>16</sub>—3 on VR<sub>2</sub>

1 on VR<sub>2</sub>—C<sub>14</sub>—2 on VR<sub>2</sub>

2 on VR<sub>2</sub>—C<sub>13</sub>—3 on VR<sub>2</sub>

2 on VR<sub>2</sub>—R<sub>15</sub>—2 on VR<sub>1</sub>

2 on V<sub>1</sub>—2 on VR<sub>1</sub>

1 on V<sub>1</sub>—C<sub>12</sub>—3 on VR<sub>3</sub>

1 on VR<sub>3</sub>—R<sub>19</sub>—2 on VR<sub>3</sub>

1 on VR<sub>1</sub>—C<sub>10</sub>—1 on VR<sub>3</sub>

5 on S<sub>1</sub>—R<sub>8</sub>—busbar

1 on VR<sub>2</sub>—R<sub>17</sub>—busbar

1 on V<sub>3</sub>—2 on VR<sub>3</sub>

1 on VR<sub>3</sub>—busbar

**Stage 4.**—Insert capacitors and resistors through rivets on group board (also straps on 21 and 24) as shown, and bend wire outwards (1). Turn group board over (making sure it is the right way round) and wire up as shown (2). Group board may be marked A and B, 1-26 to facilitate wiring.

**NOTE.**—Keep R<sub>24</sub> clear of group board and other components.

#### POINT-TO-POINT CHECK

##### Stage 4 (1)

B3—C<sub>21</sub> and R<sub>33</sub>—A3

B4—R<sub>21</sub>—A4

B5—neg. C<sub>7</sub> and R<sub>9</sub>—A5

B6—neg. C<sub>8</sub> and R<sub>13</sub>—A6

B7—R<sub>11</sub>—A7

B8—R<sub>10</sub>—A8

B9—C<sub>6</sub>—A9

B10—neg. C<sub>17</sub> and R<sub>22</sub>—A10

B11—neg. C<sub>16</sub>—A11

B12—R<sub>24</sub>—A12

B13—R<sub>31</sub>—A13

B14—R<sub>23</sub>—A14

B15—C<sub>19</sub>—A15

B16—R<sub>32</sub>—A16

B17—R<sub>28</sub>—A17

B18—R<sub>27</sub>—A18

B19—C<sub>18</sub>—A19

B20—R<sub>18</sub>—A20

B21—A21

B22—neg. C<sub>15</sub> and R<sub>20</sub>—A22

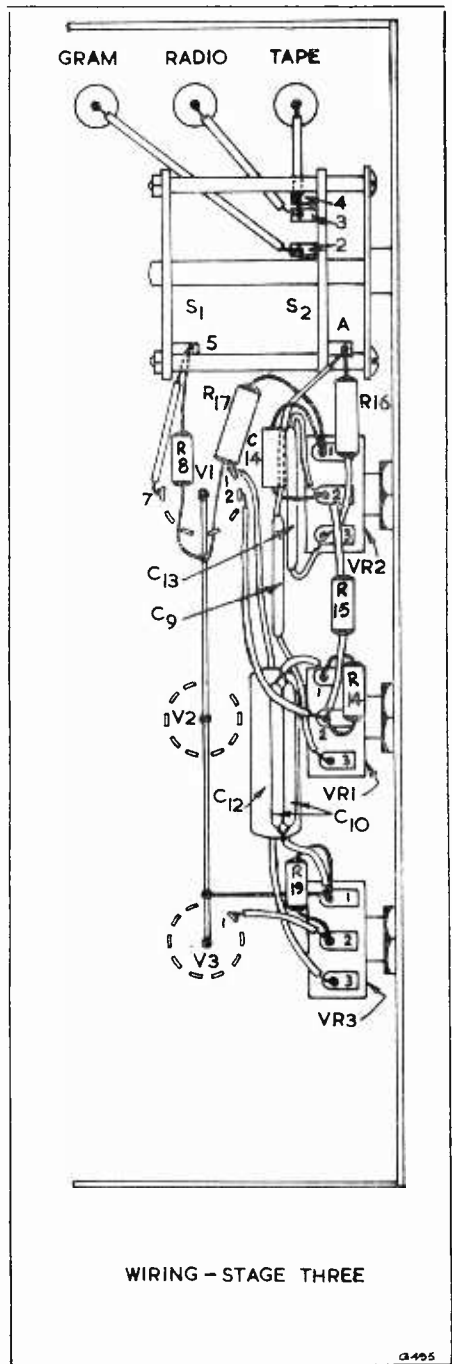

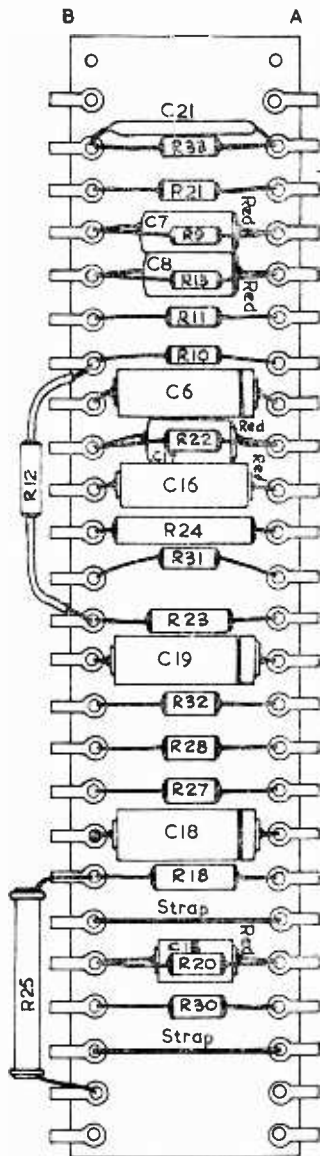

(1)

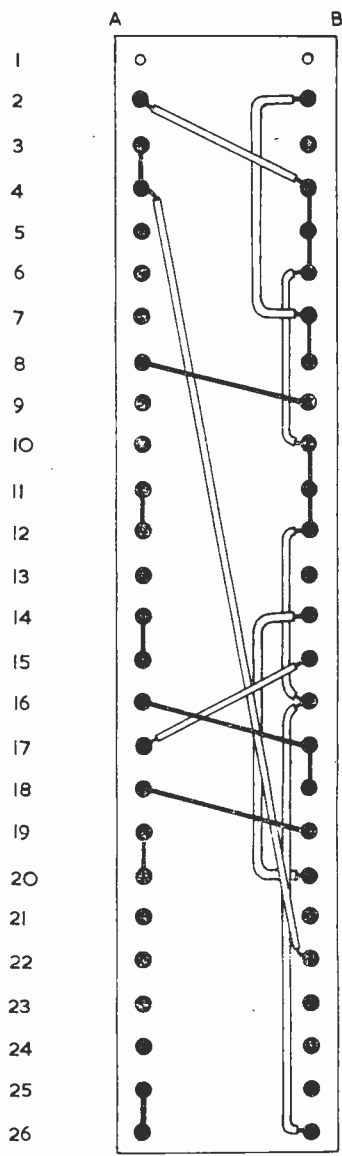

(2)

WIRING - STAGE FOUR

G496

B23—R<sub>30</sub>—A23  
 B24—A24  
 B8—R<sub>12</sub>—B14  
 B20—R<sub>25</sub>—B25

Stage 4 (2)

A2—B4—B5—B6—B10—B11—B12—B16  
 —B26  
 A3—A4—B22  
 A8—B9  
 A11—A12  
 A14—A15  
 A16—B17—B18  
 A17—B15  
 A18—B19  
 A19—A20  
 A25—A26  
 B2—B7—B8  
 B14—B20

B5, B6, B7, B8 (keep these clear of connection from pin 7, V<sub>1</sub>). B9, B10, B12, B13, B14, B16, B21, B17, B18, B20, B22, B23, B24.

POINT-TO-POINT CHECK

Stage 5

B2—pos. C<sub>1</sub>—A2—Solder tag  
 B3—1 on output socket  
 B4—2 on output socket  
 B13—orange lead from T<sub>2</sub>  
 B14—C11  
 B21—brown lead from T<sub>2</sub>  
 B23—yellow lead from T<sub>2</sub>  
 B24—green lead from T<sub>2</sub>  
 B25—3 on V<sub>4</sub>  
 B25—R<sub>34</sub>—A25—3 on power output socket  
 B26—neg. C<sub>20</sub>—A26

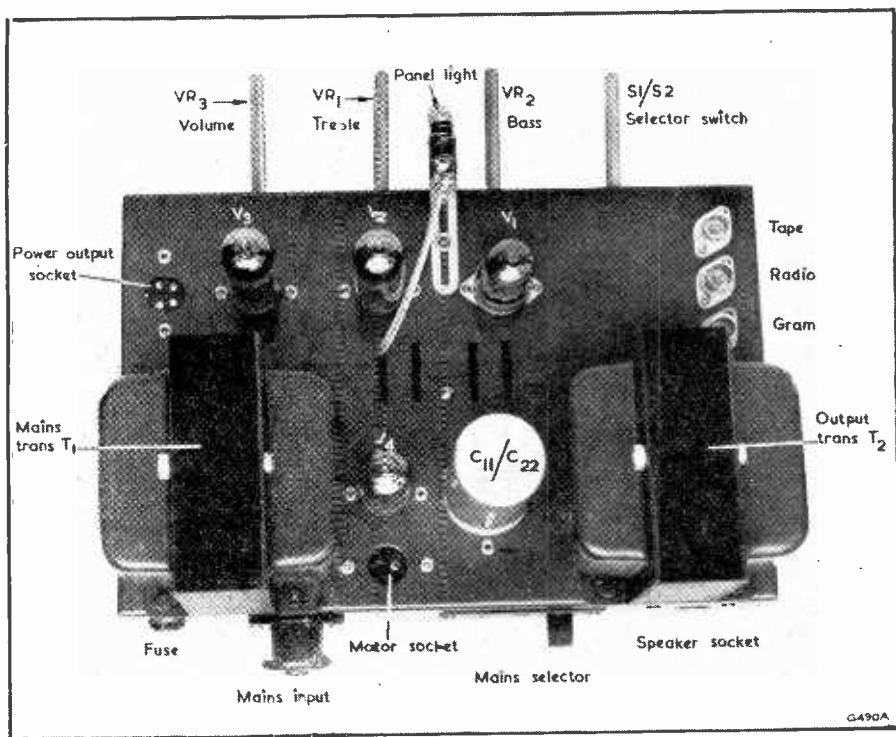

Cooper-Smith "Prodigy", layout above chassis

Stage 5.—Put a nut on each of the three long screws about  $\frac{1}{4}$  in down the thread, fit group board and wire up as shown, adding C<sub>1</sub>, C<sub>20</sub> and R<sub>34</sub>. The best sequence for wiring up to the valveholders is as follows:—

A5—8 on V<sub>1</sub>  
 A6—3 on V<sub>1</sub>  
 A7—1 on V<sub>1</sub>  
 A8—6 on V<sub>1</sub>  
 A9—A on selector switch

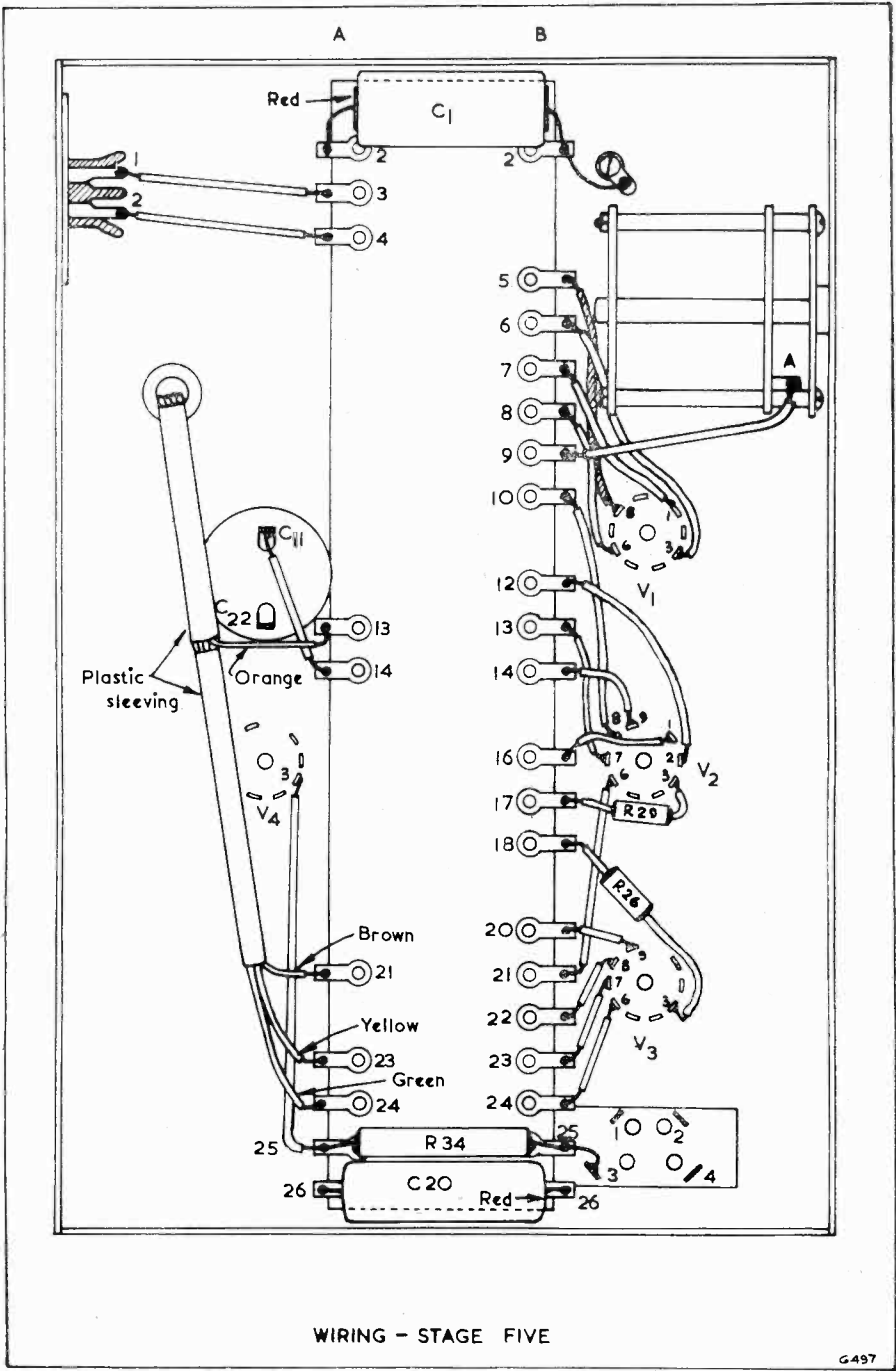

WIRING - STAGE FIVE

G497

A10—8 on V<sub>2</sub>  
 A12—2 on V<sub>2</sub>  
 A13—7 on V<sub>2</sub>  
 A14—9 on V<sub>2</sub>  
 A16—1 on V<sub>2</sub>  
 A17—R<sub>29</sub>—3 on V<sub>2</sub>  
 A18—R<sub>26</sub>—3 on V<sub>3</sub>  
 A20—9 on V<sub>3</sub>  
 A21—6 on V<sub>2</sub>  
 A22—8 on V<sub>3</sub>  
 A23—7 on V<sub>3</sub>  
 A24—6 on V<sub>3</sub>

### The Power Output Socket

The Power Output Socket is incorporated in the amplifier to enable the user to obtain readily h.t. and l.t. for supplying ancillary apparatus such as a radio tuner or tape pre-amplifier. As these rarely need as much as 250V h.t., provision is made on the group board for a dropping resistor (R<sub>34</sub>), which cannot be included in a kit or built-up amplifier as its value will depend on the voltage and current required. This may easily be calculated by Ohm's Law, for example:

It is desired to use a tuner requiring 200V at 35mA, so the voltage to be dropped is 50.

The formula is  

$$\frac{\text{Voltage to be dropped}}{\text{Current in mA}} \times 1,000 = \text{Ohms}$$

$$\frac{50}{35} \times 1,000 = 1,430\Omega$$

The nearest stock value being 1,500Ω, this would be the resistor to be asked for when ordering.

Decoupling is already provided by C<sub>20</sub>. Connections to the plug should be made to the pins which correspond to the numbers on the socket, as follows: Pin 3, h.t.+. Pin 4, h.t.—. Pins 1 and 2, l.t.

The output transformer secondary is wound in three separate sections, correct speaker matching being achieved by a series/parallel arrangement. The three speaker impedances are matched to the amplifier by wiring the speaker plug in accordance with the diagram shown on page 197 of the October issue. This minimises the amount of re-wiring inside the amplifier. However, each loudspeaker impedance calls for different values of feedback resistor and capacitor.

For 15Ω R<sub>33</sub>=680Ω, C<sub>21</sub>=3,000pF.

For 7.5Ω R<sub>33</sub>=560Ω, C<sub>21</sub>=3,500pF.

For 3.75Ω R<sub>33</sub>=470Ω, C<sub>21</sub>=4,000pF.

Before switching on the amplifier, thoroughly check the wiring and, if a continuity meter is available, connect between the positive side of C<sub>22</sub> and earth. If all is well, the needle will kick and then return slowly to zero. If the needle remains at full scale, a short circuit is indicated and the amplifier must not be connected to the mains until the fault has been rectified. Of all the faults which may exist, this is the most important as it will cause damage to components and rectifier valve if not put right.

Do not switch on the amplifier without first connecting the loudspeaker.

With the specified components, and careful work on your part, all should be well. Should any difficulty arise, however, contact Jack Cooper of H. L. Smith & Co. Ltd.

### Transformer Specifications

*Mains Transformer:* Primary 0-200-220-240V. Secondaries 250-0-250V at 100mA, 3.15-0-3.15V at 4A, 6.3V at 2A.

*Output Transformer:* Primary 10kΩ anode-to-anode, ultra-linear taps 43%. Secondary wound in 3 separate sections. Speaker matching achieved by series/parallel arrangement. 15Ω 7.5Ω 3.75Ω. Primary inductance 58H at 30V 50 c/s. Leakage inductance 0.5mH at 1V, 1,000 c/s.

## PANEL-SIGNS TRANSFERS

### Set No. 1: Receivers and Amplifiers

Five sheets 8½" × 5½" containing one Large scale, twelve control panels and white wording. 3s. 6d. Postage 2d.

### Set No. 2: Test Equipment

Five sheets 8½" × 5½" containing two Medium scales, twelve control panels and white wording. 3s. 6d. Postage 2d.

### Set No. 3: Wording

Wording for Receivers, Amplifiers, Transmitters, Test Equipment and other Radio Apparatus, and Station Names. Five sheets, over 750 words and symbols. White. 3s. 6d. Postage 2d.

### Set No. 4: Wording

As set No. 3, but in black. 3s. 6d. Postage 2d.

# MODELS FOR RADIO CONTROL

## THE "WAVEMASTER" KIT

### Part 4

by Raymond F. Stock

#### Electric Drive

WHEN A REDUCED PERFORMANCE CAN BE accepted, electric drive may be indicated and will, of course, simplify control. Installation then becomes very simple. Several types of surplus low voltage motors can be used and will, in general, be held down by metal straps screwed to a block glued down to the bottom of the hull. Circular-section motors may rest in a shaped saddle of wood.

selected, or the components may be made at home.

The general form of construction suited to hand tools is shown in Fig. 3. An outer tube may be cut from a length of thin-walled seamless steel tube, and certain surplus whip aerial sections can be used here; alternatively, brass tube can be employed. In each end is inserted a short bearing of brass or, preferably, a bronze bearing material, soft-soldered into place.

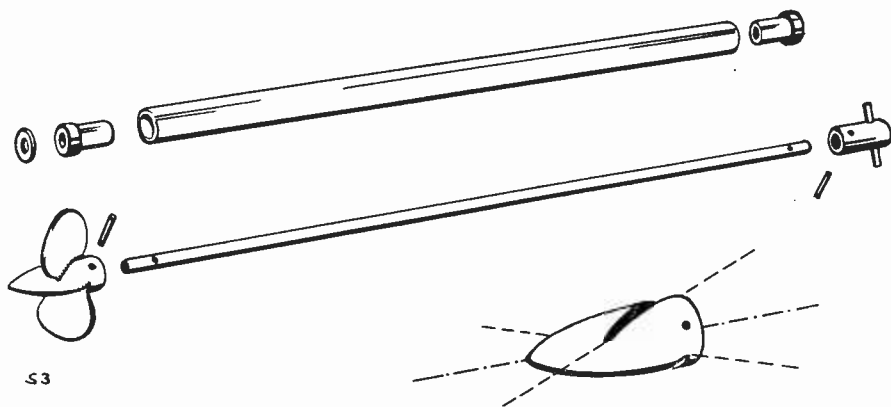

Fig. 3. Simply made components for a propeller, shaft, coupling and shaft tube. The bushes are soldered into the tube. The larger view of the hub shows how the slots are made by angled saw cuts

The *Wavemaster* is provided with a partly cut slot through the keel which is opened out during building to take a propeller shaft and tube. The complete unit may be purchased from model shops, a suitable size being

The shaft should be of silver steel rod, or, if obtainable, rustless ground bar. For a boat of this size  $\frac{1}{8}$  in diameter should be regarded as the minimum (for electric drive) or up to  $\frac{3}{16}$  in when a powerful I.C. engine is



fitted. The inboard end should terminate in a half coupling to mate with that on the motor, and some form of flexible drive using a rubber component is useful in promoting quiet running.

most important and is quoted (indirectly) as the *pitch* of the propeller. This may be calculated from the estimated speed of the complete model, though unfortunately a good deal of experience is required to assess the

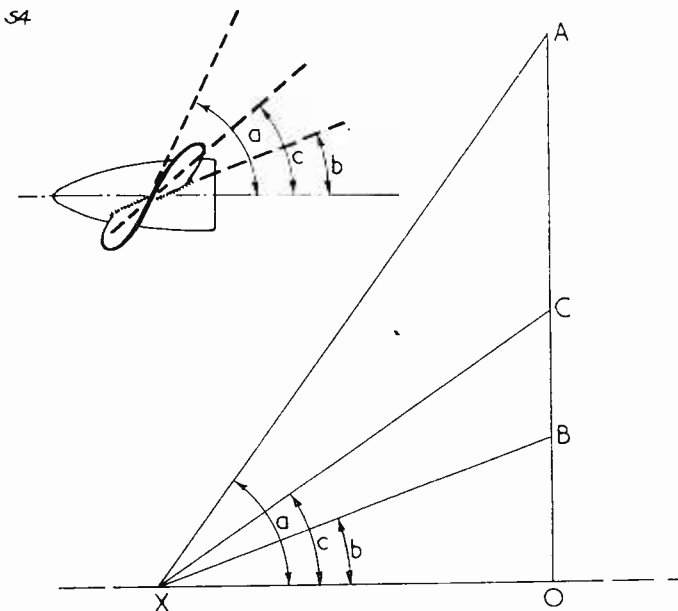

Fig. 4. X-O = Pitch.  
A-O = Circumference at tip

### Propellers

A small volume could be devoted to propeller design, and it is impossible to quote exact sizes. The biggest mistake usually made is to fit too large a propeller (in either diameter or pitch), as this slows down the motor to an inefficient speed; this applies both to I.C. and to electric drive. A "cut and try" method is usually best, simple soft-soldered screws being used until the optimum size is found, after which a more elaborate model can be made. There is no justification for using more than two blades, and these may be cut from 16 s.w.g. brass sheet, hard-soldered (for a finalised component) into saw cuts in a circular brass hub. The latter can be "turned" to shape with a file if mounted in an electric drill chuck. It should be attached to the shaft by cross-pinning with a  $\frac{1}{16}$  in steel pin.

The blades should be of a rounded form (this is not a critical factor) and, if made deliberately oversize, trimmed down with cutters and a file *in situ* to achieve the best performance. The angle of the blades is

latter. Ideally, one assumes a certain speed—say, two knots plus (for an electric model). This equals 6,000 x 2 feet per hour = 200ft/min. If the motor is intended to run at 1,000 r.p.m. each revolution must advance the boat  $\frac{200}{1,000}$  ft or 0.2ft. Allowing a 25% slip (since the screw is not working in a solid medium), the screw should have a pitch of 1.25 x 0.2ft = 3in.

Fig. 4 shows a graphical method of determining blade angle. The base is made 3in long (X-O) while the vertical height of the triangle is made equal to the circumference of the propeller (A-O). Drawing a diagonal line (A-X) then represents the angle of the blade tip relative to the shaft, at (a). Similarly, (B-X) is drawn to the point representing the circumference of the hub and (b) represents the angle of the blade root (and the saw cut in the hub). (C-X) and (c) refer to a station at half the blade height; these three angles should be checked on each blade as it is twisted. The blades are, of course, inserted and soldered into the hub whilst in

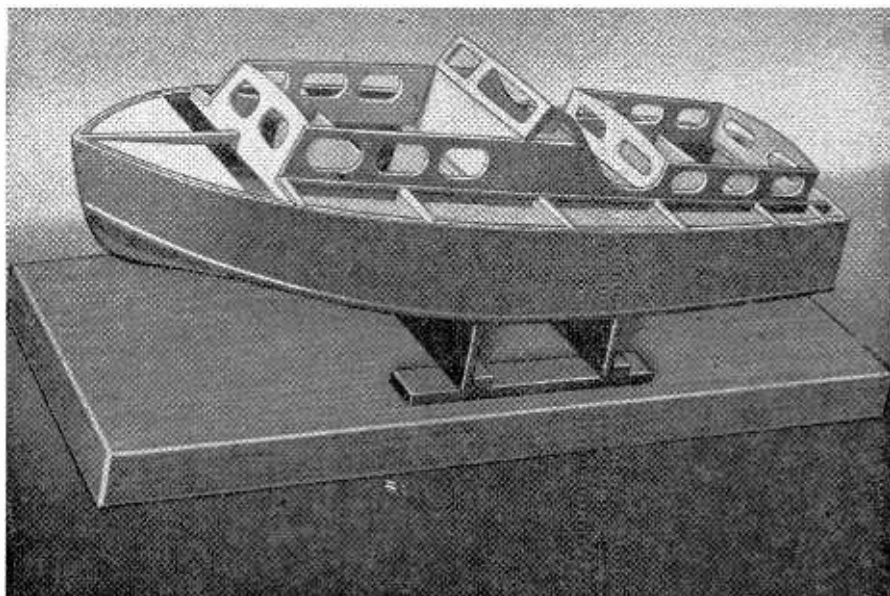

Fixing the superstructure

the flat, and something like a correct twist should result if each blade tip is gripped by a pair of flat nose pliers and turned.

Soft soldering is *not* adequate for retaining the blades on a model powered by a large electric motor or by an I.C. engine. Silver solder *must* be used, a neat fillet being left

and filed smoothly into the contour of both hub and blade. A steel washer should be trapped between the boss and the after-tube bearing to absorb propeller thrust. In use, the tube should be packed with light grease or thick oil.

## Radio **HOBBIES** Exhibition

EXHIBITORS AS AT 6th OCTOBER 1958

	<i>Stand No.</i>		<i>Stand No.</i>
British Amateur Television Club ..	34	The Minimiter Co. ..	13
British National Radio School ..	5	Mullard Limited ..	26
Clyne Radio Ltd. ..	28	E. J. Philpott's Metalworks Ltd. ..	15
Cossor Instruments Ltd. ..	—	Premier Radio ..	16
Data Publications Ltd., <i>Radio Con-</i>	29	Racal Engineering Ltd. ..	24
<i>structor</i> ..	29	Radio Society of Great Britain ..	1
Daystrom Ltd. (Heathkits) ..	—	Relda Radio Ltd. ..	9
Enthoven Solders Ltd. ..	23	Royal Air Force ..	4
Home Radio (Mitcham) Ltd. ..	20	Royal Navy ..	25
Iliffe Press Ltd., <i>Wireless World,</i>	22	Army ..	33
<i>Electronic and Radio Engineer</i> ..	22	<i>Short Wave Magazine</i> ..	14
Jason Motor & Electronic Co. ..	18	Standard Telephones & Cables Ltd. ..	17
K.W. Electronics Ltd. ..	8	Taylor Electrical Instruments Ltd. ..	6
London Electric Wire Co. & Smith's	27	Teleton Ltd. ..	31
Ltd. ..	27	Whiteley Electrical Radio Co. Ltd. ..	35
London U.H.F. Group ..	3	Colour Television G3ILI/T ..	35

# Visit to Siemens Edison Swan

## Sunderland TV Tube Factory

The writer recently formed one of a party of radio and engineering journalists who flew north in a Viking aircraft, at the invitation of Siemens Edison Swan Ltd., to their model t.v. tube factory at Sunderland. The flight from Blackbushe to Newcastle airport took a little over an hour and a quarter, a speed of 230 m.p.h. at a height of 8,000 feet being set most of the journey.

From the latter air terminal, a coach was provided for the run to the factory situated in ideal surroundings on the outskirts of Sunderland. After an excellent lunch, the writer was admirably conducted around the factory by Mr. Potts of the Engineering Division.

Mass production of t.v. tubes at this factory is currently running at 12,000 a week, and the use of automatic methods enables the entire manufacture to be carried out by a minimum of operators. The factory runs continuously through 15 shifts from Monday morning to Saturday morning inclusive. The total number of employees at the factory is around 660.

### The Manufacturing Processes

The making of Ediswan-Mazda t.v. tubes is carried out by a series of automatic processes linked by nearly two miles of overhead conveyors. The equipment is estimated to be worth £1½ million. It has been designed, much of it to the company's own specification, for the single purpose of making cathode ray tubes.

The glasswork consisting of face, back and neck is first placed in pre-heating ovens and brought slowly to an appropriate temperature. The backs are then joined to the necks and transferred to a circular machine which makes the anode hole and drops in the anode button. After annealing they are inspected and the completed backs are then joined to the pre-heated faces by the electrical face sealing technique. The finished bulbs enter a lehr which gradually cools them after holding them for a certain period at a high temperature, in order to allow the glass to "settle," after which they are again inspected.

In the bulb-washing section, where surface contamination is removed, the bulbs pass various jets of chemicals and demineralised water rinses. There is also a similar process for reclaimed bulb-washing using different proportions of chemicals.

### Screening the Faces

Screening of the faces now follows on a giant conveyor. Barium acetate and water are poured into the upturned bulbs in quantities according to tube size, phosphor powder and silicate are added, and the

mixture allowed to settle for 20 minutes. With the screen now formed, the tube reaches the end of the conveyor where decantation of the liquids takes place, the tube returning on the underside of the conveyor to the take-off point. Inspection of the screen under a fluorescent light now takes place. The screen is next coated with a bedacryl and turline solution which provides a plasticiser to protect the coating at the subsequent aluminising operation.

Tubes are now placed on a conveyor to dry out by means of hot air pokers. Aquadag, a graphite solution, is now applied inside the neck to give contact between the anode button and the gun, which latter is subsequently inserted.

The aluminising process, which is fully automatic, comprises several stages of evacuation. After vacuum check the aluminium is volatilised, thus forming a mirror behind the screen. There is a further inspection at this stage.

Aluminised tubes are now fed into a 120ft long bake lehr, and receive a four-hour treatment. A rigid inspection with the aid of ultra-violet light now takes place, only those screens without any trace of blemish being allowed to go forward.

### Inserting the Guns

The guns, comprising anodes, grid, cathode and heater are now inserted into the necks. These "mount assemblies" arrive complete from another Siemens Edison Swan factory in Sunderland. The marrying of gun to neck is an extremely fine operation with little permissible tolerance, as it is at this point that the distance from gun to screen is set.

Evacuation of the tube follows on in-line exhaust machines. These embody conveyors carrying 159 exhaust cubicles each. Every cubicle is an exhaust machine in its own right. The cubicles move round one station at regular intervals between 30 and 60 seconds. Different size tubes can be evacuated simultaneously on the in-line machine as each cubicle may be separately adjusted. During this process, not only is it necessary to remove the air, but also to heat all parts inside and outside to various temperatures by means of radio frequency heating and external baking of the bulb. Cubicles are withdrawable in event of a fault arising. The cap base is now added, after which r.f. heating of the barium getter is carried out. This removes from the tube any final traces of residual gas.

*continued on page 301*

---

## Mullard Tape Amplifier "Type C" *continued from page 285*

### H.F. Oscillator Stage

This stage is designed to work with the two triode halves of an ECC82 valve working in push-pull into a Ferroxcube cored oscillator coil, L<sub>1</sub>, L<sub>2</sub>. During playback, when it is inoperative, the circuit draws approximately the same current as during the oscillatory condition for recording. With little or no change of current for the two conditions, the design of the power supply is simplified. The push-pull circuit effects a current saving over the earlier version and enables a lower distortion figure to be achieved. The erase current is obtained off a tap on the secondary winding. Switch wafers SA<sub>5</sub>, SA<sub>7</sub> and SA<sub>8</sub> of the record/playback switch are used to

switch the output, earth the circuit on playback and switch h.t. respectively as required.

### Recording Level Indicator

The tuning indicator, type EM81, used in this stage is fed from the anode of the recording stage through a large series resistance R<sub>18</sub> to minimise the loading of the recording stage.

### Assembly and Wiring

The list of components required will enable intending constructors to start collecting or to place orders for the complete kit as advertised in this issue. Next month full wiring details will be given.

A.....



.....

# Transistor Receiver

By J. C. BAKER

DETAILS OF TRANSISTOR RECEIVERS HITHERTO published appear to fall into two classes: the very simple circuits consisting of one or two transistors and very little else, and elaborate superhets. The former, although they give the beginner some insight into basic circuits, are of little actual value; while the latter are far too difficult to build and expensive for many home constructors.

ferrite rod aerial is tuned by a 500pF variable condenser in the usual way and an extension of this winding forms the secondary of a step-down transformer, the output of which is fed to the base and emitter of the first transistor. A small part of the resulting collector current is fed back to the aerial through the 30pF preset reaction condenser, while the remainder is fed to the two ger-

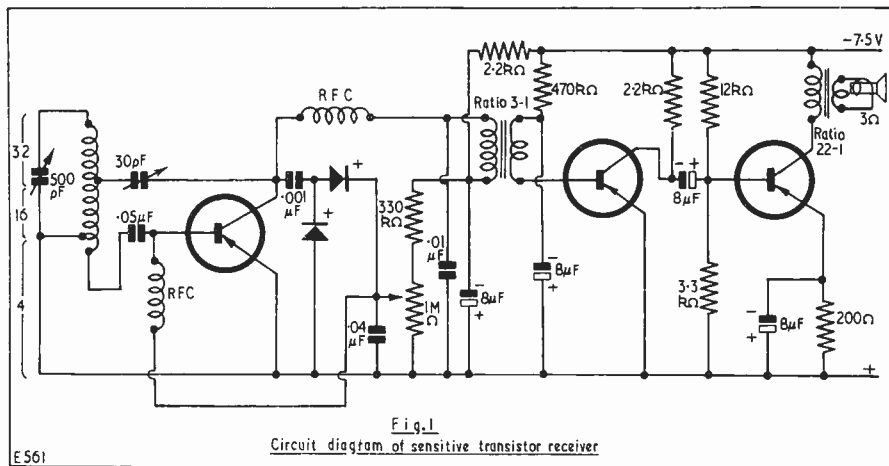

In the present article it is intended to describe a circuit which can be regarded as midway between these extremes. Assessing the performance of any set without extensive laboratory tests is difficult. It could be mentioned as a rough guide that in the London area Home, Light, Third and Hilversum can be received at full loudspeaker strength; and with careful adjustment of reaction several French and German stations can be received. The selectivity is good, being comparable to that of many superhets.

Incidentally, the writer claims no originality for the idea, which is a modification of a Japanese pocket receiver described in an American magazine.

Referring to Fig. 1, the winding on the

manium diodes arranged as a voltage doubler detector. The a.f. current so obtained is fed back via RFC<sub>1</sub> to the base and emitter of the r.f. transistor. This principle of using the same device for r.f. and a.f. amplification simultaneously is known as reflex working and was popular in the early days of broadcast receivers. The collector a.f. output is fed via RFC<sub>2</sub> to the primary of the interstage transformer and the remainder of the circuit follows accepted practice.

Although the dimensions and layout of the receiver can be arranged to suit individual requirements, for maximum performance the ferrite rods should be eight or nine inches in length. Also, the speaker should be as large as circumstances permit. Assuming the

cabinet will be of such dimensions as to accommodate a 7in or 8in ferrite rod, it is suggested that a 7in x 4in elliptical speaker be used. This is a standard size of which there are many makes available. The "Elac" is a good example; it is inexpensive and has an excellent frequency response. All small components should be mounted on a tag-board secured to any convenient part of the cabinet, a metal chassis being quite unnecessary. The general layout should be such that there is some vacant space near the top of the cabinet in order that the ferrite rod can be fastened horizontally and not be near to any large metal objects, such as the speaker chassis.

As the aerial assembly is an important item, its construction will be considered in some detail (see Figs. 2 and 3). Two ferrite rods 8in x  $\frac{3}{8}$ in dia. are mounted side by side and the coil is wound (on a paper tube) round the rods. This coil assembly should be capable of being moved along the rods in order to find the most sensitive position. This will not be the centre of the rods, but roughly one-third of the length. Although reasonably good results can be obtained with almost any sort of wire, for maximum efficiency "Litz" wire should be used. When the winding is put on, it exerts considerable inward (crushing) pressure and unless the right method is adopted it will be found that the coil former is pressed so firmly to the rods that it will be impossible to move it. To obviate this, proceed as follows: first, fit two paper tubes round the rods. That is, one paper tube about three inches in length round each rod. Two turns of paper should be sufficient. Secure with "Durafix," but try to avoid sticking the tubes to the rods. Bind the tubes with string or wire until dry. When dry, remove the lashings and place the two rods beside one another so that the paper tubes are level. Now wind three turns of stiff paper over this assembly to form a sort of oval tube; glue and bind as before. When the binding has been removed, the coil is wound on this tube, making tappings at the appropriate points. When complete, it will be found that the coil assembly cannot be moved along the rods. Mount one ferrite rod vertically in a vice—first covering the

jaws with felt. If the other rod is gently tapped with a piece of wood it can be driven gradually out. The paper tubes are now removed from the rods and upon re-assembling it will be found that there is now sufficient clearance to permit free movement of the coil.

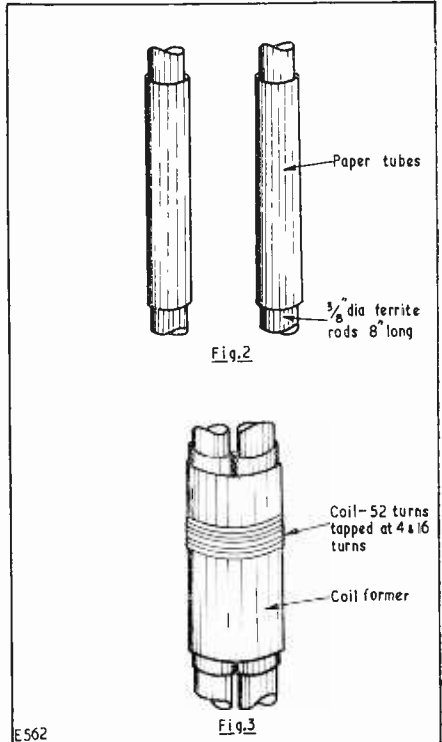

The only other point requiring comment is the choice of transistors. The first (r.f.) transistor should be of known make and characteristics. In the second stage, much greater latitude is permissible; in fact almost any transistor can be used. It should, however, be reasonably free from background noise. The Mullard OC72 is excellent for the output stage.

## THE RADIO CONSTRUCTOR

### BOUND VOLUMES (complete with index)

Attractively bound in blue cloth, with gold-blocked spine

Vol. 10, August 56 to July 57 .. ..	£1.5.0, postage 1/9
Vol. 11, August 57 to July 58 .. ..	£1.5.0, postage 1/9

Where readers return all issues of a volume for exchange 12/6, postage 1/9

DATA PUBLICATIONS LTD 57 Maida Vale London W9

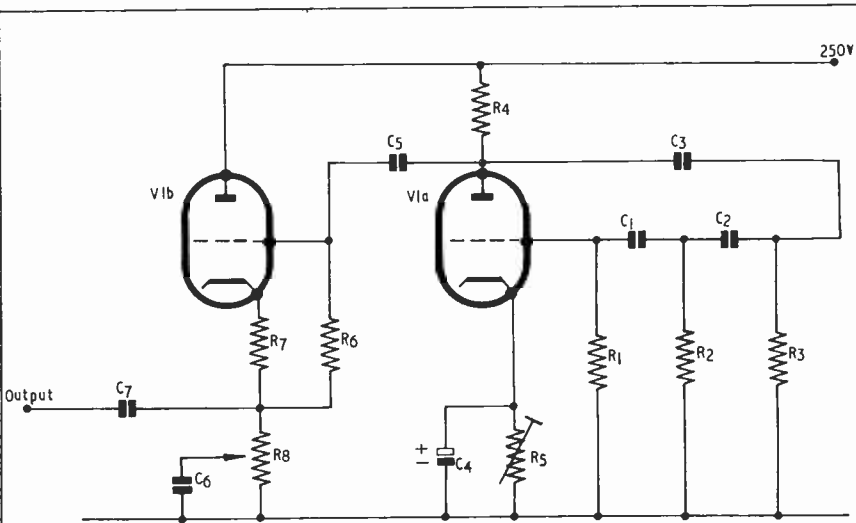

Fig. 1

Component list

- |                       |                          |
|-----------------------|--------------------------|
| R1-R2-R3—180RΩ ¼ watt | C1-C2-C3—1000pF ceramic  |
| R4—47RΩ ½ watt        | C4—50μF 12V electrolytic |
| R5—10RΩ preset pot    | C5-C7—0.05μF 350VW       |
| R6—470RΩ ¼ watt       | C6—8μF 150VW             |
| R7—390ohms ¼ watt     | V1a-V1b—12AT7, ECC81 etc |
| R8—10RΩ ww pot        |                          |

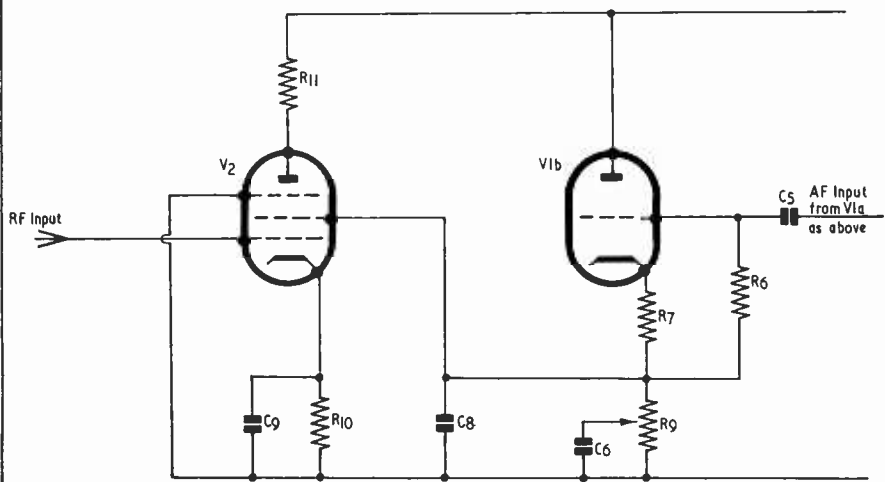

Fig. 2

Additional components list

- |                     |                    |
|---------------------|--------------------|
| R9—20RΩ ww pot      | C8—100pF sm        |
| R10—150 ohms ¼ watt | C9—0.01μF 150VW    |
| R11—4.7RΩ ½ watt    | V2—EF 80, EF91 etc |

# A VERSATILE

## Audio Frequency Oscillator

By D. E. VAUGHAN

THE PURPOSE FOR WHICH THIS CIRCUIT was originally devised required a compact source of audio frequency possessing good waveform, reasonably constant frequency and variable amplitude. The writer thinks that a simple circuit with such characteristics might be of general interest.

As compactness and low weight were of primary importance, the use of transformers or chokes was out of the question; so it was necessary to investigate the so-called R-C oscillators. The circuit which was finally chosen is shown in Fig. 1. It consists of a phase shift oscillator feeding into a cathode follower, the whole circuit being constructed around an easily obtainable double triode. If, as is usual with this circuit,  $C_1=C_2=C_3$  and  $R_1=R_2=R_3$ , then the approximate frequency of oscillation is given by

$$f = \frac{1}{2\pi C_1 R_1 \sqrt{6}}$$

Variation of frequency over a limited range is best obtained by making  $R_2$  variable, although this is not provided for in the circuit given. The component values listed give a frequency of about 400 c/s, which is a standard test frequency. Other frequencies can be obtained with component values calculated from the formula given above.

No constructional details are given since the layout is not critical. This means that the unit can be built into any convenient space, with most of the components attached to the valveholder tags.

The only adjustment required to set up the instrument is to the value of  $R_5$ . It will be found that oscillation occurs only between narrow limits, and the control should be adjusted to the midpoint of this range.

The current requirements of the circuit are extremely modest, about 3mA for the oscillator and about 5mA for the cathode follower with an h.t. line of 250V.

Because of its good waveform, this oscillator is particularly suitable for use as a source of modulation for a signal generator. It is not always appreciated that good

waveform is necessary for this purpose, but the presence of high order harmonics of the modulating frequency will produce sidebands, well spaced from the carrier, which can be very troublesome in alignment work.

A particularly satisfactory modulator, based on the audio oscillator just described, is shown in Fig. 2. It is a screen modulated pentode fed from the oscillator through a cathode follower, directly coupled to the screen. Through using an additional valve it has the advantage over the usual system of eliminating interaction between the audio frequency and radio frequency oscillators. This means that modulation depths approaching 100% can be obtained without affecting the carrier frequency. Suitable valves for the modulator are EF80 or EF91, but it is possible to use the pentode section of an ECF82 as the modulator and to use the triode section as the radio frequency oscillator.

In addition to its use as a modulator as described above, the oscillator can be used for energising an a.c. bridge, and applied to the general testing of audio frequency equipment. Other experiments will doubtless find still further uses.

### Visit to Siemens Edison Swan Sunderland TV Tube Factory *continued from page 297*

#### Running-in the Tubes

Electrical ageing or "running-in" of the tube follows, the object being to stabilise tubes which are in various stages of activation. Ordinary ageing is followed by high voltage ageing which entails bombarding of emissive spots to obviate spurious emission. Complete electrical and picture tests are now made. Before dimensional inspection, the conical section of the bulb is externally coated with aquadag to a specified thickness. This provides the t.v. setmaker with a ready-made capacitance between the internal aluminium film and the external aquadag.

At the packing station, the tube undergoes a final inspection. Finished tubes are then packed and despatched either in single boxes or in the more economical multi-packs which take 6, 12 or 15, according to type of tube.

This month, the Sunderland factory completed its one millionth t.v. tube since manufacture began three years ago.

# a power-unit

THE POWER-UNIT ABOUT TO BE DESCRIBED was constructed by the author, a few months ago, to fulfil two main purposes. They were: (1) To find a use for a homeless mains transformer which had been moved from shelf to shelf in the workshop over the past three years; (2) To provide a continuously variable h.t. power supply for test and experimental purposes.

The results in both cases were found to be quite satisfactory.

The total expenditure was the cost of the solder used to hold the job together; and, using the basic principle of the circuit, most readers will no doubt find that they too can provide a use for a few oddments cluttering up the shack.

It will be seen that the EL38 is simply placed in series with the h.t. positive side of the output from the rectifier, and that the bias applied to the control grid,  $g_1$ , is used to control the current through the valve. Hence the voltage drop across it is controllable—resulting in a continuously-variable output.

It will be seen that the bias supply is derived from a potentiometer across the output from the rectifier.

It could be obtained by putting the potentiometer across the actual output (which is probably the safer method) but then a certain amount of control would be lost as the bias available becomes dependent on the h.t. output.

The former method is by far the most

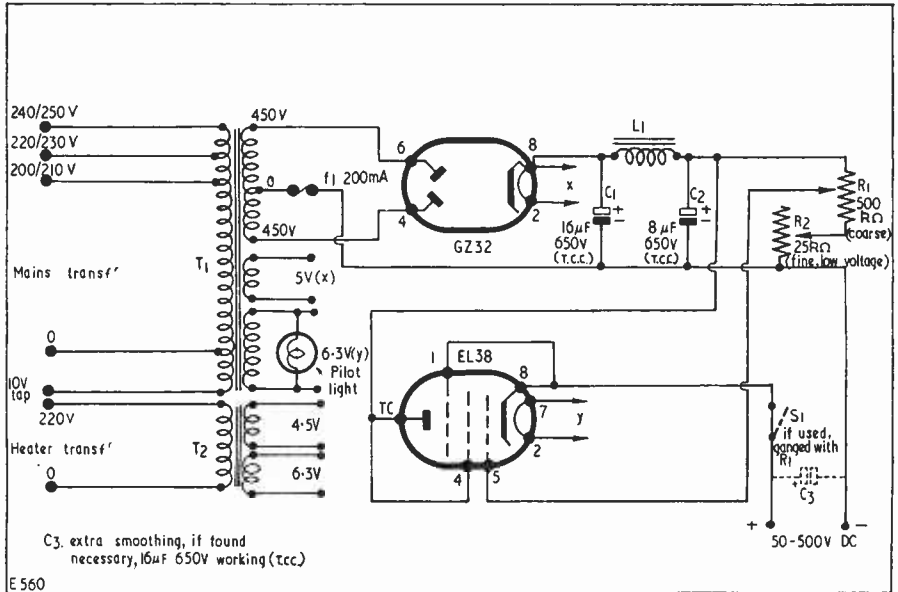

## Circuit

A quick glance at the circuit will show that the most fundamental characteristic of a Multi-grid Valve is being put to good purpose.

satisfactory, and although under certain conditions the potential between  $g_1$  and cathode may become quite high, it is found in practice that the EL38 can take the strain without any shadow of complaint.



# with a difference

By R. S. SQUIRES

As a test, the unit constructed by the author was run continuously for a period of approx. 75 hours at a voltage of 45 volts and a load of 100mA. The EL38 did not even become as warm as it does when employed in more conventional circuits.

The h.t. output should be isolated from the container, and offered only at the h.t. output terminals. There will then be little chance of an accident if the unit is adjusted whilst connected to any external apparatus.

It will be noticed that a heater-transformer is included in the circuit to provide l.t. for test purposes. This is, of course, quite optional—but *very* useful.

The unit can be constructed in any box of convenient size, either wood or metal. The layout is not in the least important apart from one small consideration; the lead from the potentiometer “wiper” to  $g_1$  of the EL38 should be kept short in order to prevent any hum being picked up and applied to the grid.

All the controls, pilot light, mains switch and output terminals should be mounted on what is to be the front panel of the unit. But this is more for the sake of convenience rather than from a technical standpoint.

The author's unit was constructed in a metal box measuring 10½in x 6in x 3in. Things were a little cramped in this case, but the actual size of the container chosen will depend to a large extent on the contents of the constructor's “junk box.”

There are several variations from the suggested circuit. The chief requirement of the valve used as a “dropper” is that the dissipation of the EL38 is given as:

Anode 25 watts  
Screen 8 watts

This is adequate for our purpose and any valve with similar characteristics could be used.

It was mentioned earlier that a *separate* heater-transformer was included in the unit for l.t. output. Some readers may wonder why the two heater supplies available for the

GZ32 and EL38 are not utilised. The main reason for this is, of course, that if, for instance, the EL38 heater were to be used also as the heater supply for a radio under test, then the potential which exists between heater and cathode of the EL38 would also exist between heater and cathode of most of the other valves in the set. And they may *not* be able to survive.

Finally, the author would welcome any suggestions for improvements to the unit; especially if a small modification could provide 0 to 500V instead of 50 to 500V.

## BRIDGE COMPONENTS

*If you require a stockist of High Grade Components, we are the people for the job.*

**If you are fitting converters,  
Why not fit the best?**

**The Brayhead Turret Converter** available for all channels from stock. Price **£7.7.0**, with adaptor 7/- each extra. Order, stating channels required (two as specified by you supplied with converter—extra channels **£1.1.0** extra). Normal trade discount—full fitting information available from:

**The High Fidelity Co**

**18 MELVILLE ROAD EDGBASTON  
BIRMINGHAM 16**

(Proprietors Kendall & Mousley Ltd)



The  
**Cooper-Smith**  
**"Prodigy"**  
**High Fidelity Amplifier**

**COMPONENT PRICE LIST**

Buy direct from the Designers to ensure 100% results  
 All enquiries promptly dealt with

R1	10M $\Omega$ high stability $\frac{1}{2}$ W	...	...	6d.
R2	390k $\Omega$ high stability $\frac{1}{2}$ W	...	...	6d.
R3	680k $\Omega$ high stability $\frac{1}{2}$ W	...	...	6d.
R4	12M $\Omega$ $\frac{1}{2}$ W	...	...	3d.
R5	390k $\Omega$ high stability $\frac{1}{2}$ W	...	...	6d.
R6	180k $\Omega$ high stability $\frac{1}{2}$ W	...	...	6d.
R7	47k $\Omega$ $\frac{1}{2}$ W	...	...	3d.
R8	2.2M $\Omega$ $\frac{1}{2}$ W	...	...	3d.
R9	1.8k $\Omega$ high stability $\frac{1}{2}$ W	...	...	6d.
R10	100k $\Omega$ high stability $\frac{1}{2}$ W	...	...	6d.
R11	47k $\Omega$ high stability $\frac{1}{2}$ W	...	...	6d.
R12	100k $\Omega$ $\frac{1}{2}$ W	...	...	4d.
R13	1.2k $\Omega$ high stability $\frac{1}{2}$ W	...	...	6d.
R14	47k $\Omega$ $\frac{1}{2}$ W	...	...	3d.
R15	39k $\Omega$ $\frac{1}{2}$ W	...	...	3d.
R16	68k $\Omega$ $\frac{1}{2}$ W	...	...	4d.
R17	6.8k $\Omega$ $\frac{1}{2}$ W	...	...	4d.
R18 & 23	*100k $\Omega$ $\frac{1}{2}$ W	...	pair	1/4
R19	270k $\Omega$ $\frac{1}{2}$ W	...	...	3d.
R20	1.2k $\Omega$ $\frac{1}{2}$ W	...	...	3d.
R21	100 $\Omega$ $\frac{1}{2}$ W	...	...	3d.
R22	1.2k $\Omega$ $\frac{1}{2}$ W	...	...	3d.
R24	390 $\Omega$ wire wound 5W	...	...	2/-
R25	2.2k $\Omega$ 1W	...	...	6d.
R26	10k $\Omega$ $\frac{1}{2}$ W	...	...	3d.
R27, 28 & 32	*1M $\Omega$ $\frac{1}{2}$ W	...	set	1/9
R29	10k $\Omega$ $\frac{1}{2}$ W	...	...	3d.
R30 & 31	47 $\Omega$ $\frac{1}{2}$ W	...	pair	6d.
R33	680 $\Omega$ $\frac{1}{2}$ W	...	...	3d.
R34	(See note on power output)	...	...	1/6
	*Matched to within 5%			
VR1 & VR2	250k $\Omega$ ...	...	each	3/6
VR3	250k $\Omega$ with switch	...	...	4/6
C1	16 $\mu$ F 275V electrolytic	...	...	2/6
C2	470pF silver mica 5%	...	...	7d.
C3	270pF silver mica 5%	...	...	6d.
C4 & 5	68pF silver mica 5%	...	pair	1/-

C6, 12, 18 & 19	0.1 $\mu$ F 350V paper	...	each	9d.
C7, 8, 15 & 17	50 $\mu$ F 12V electrolytic	...	each	1/7
C9	560pF silver mica 20%	...	...	7d.
C10	8,000pF (2 x 4,000pF) silver mica 20%	...	...	2/2
C11 & 22	50-50 $\mu$ F 350V electrolytic	...	...	8/6
C13	2,000pF silver mica 20%	...	...	9d.
C14	0.02 $\mu$ F moldseal	...	...	1/-
C16	50 $\mu$ F 25V electrolytic	...	...	1/10
C20	8 $\mu$ F 350V electrolytic	...	...	2/6
C21	3,000pF silver mica 20%	...	...	1/-
V1	12AX7 (inc. P.T.)	...	...	18/11
V2 & 3	ECL82 (inc. P.T.)	...	each	22/4
V4	EZ81 (inc. P.T.)	...	...	11/6
	(No Purchase Tax is payable on the valves when included in a kit)			
	Mains Transformer (T1), A.E.E.	...	...	51/8
	Output Transformer (T2), A.E.E.	...	...	49/6
	Switch, 2-pole 4-way (S1, S2)	...	...	10/6
	Voltage selector	...	...	1/6
	Mains plug and socket	...	...	3/9
	Output plug and socket 5-pin	...	...	9d.
	Power plug and socket 4-pin	...	...	9d.
	Motor plug and socket 2-pin	...	...	7 $\frac{1}{2}$ d.
	Coaxial sockets (3)	...	each	1/3
	Coaxial plug	...	...	1/3
	Fuse, 2A, and holder	...	...	4/-
	Valveholder, with skirt	...	...	3/10
	Valveholder, paxolin (3)	...	each	6d.
	Group board, 26-way, 1 blank	...	...	4/6
	Panel light holder and bulb	...	...	1/3
	Knobs, pointer (4)	...	set	5/-
	Nuts, screws, solder tags	...	...	4/-
	Wire, flex, sleeving	...	pkt.	2/-
	Chassis, punched, bronze finish	...	...	17/6
	Base plate, with screws	...	...	2/6
	Grommets (8)	...	...	6d.
	Control Panel	...	...	12/6
	<b>TOTAL</b>	...	...	<b>£15.18.0</b>

**INCLUSIVE PRICE FOR COMPLETE KIT ... £13. 7.6**  
**LABORATORY-BUILT AND TESTED ... £16. 16.0**

Carriage free in U.K.

Send 2/8d. for Radio Reprint No. 10 (now in preparation) which gives full instructions, additional material and price list of parts

**H. L. SMITH & CO LTD**

287/9 EDGWARE ROAD . LONDON W2 . Telephone Paddington 5891 & 7595

## G2AK FOR QUALITY AND SERVICE

**HEADPHONES, H.R. type.** 4,000 ohms. Very sensitive, only 12/6 pair, post 1/6. **C.L.R. type** (low res.) 8/6, post 1/6

**ACOS MIC. 32/2.** New in maker's cartons. List 55/-. Our Price 35/-. P. & P. 1/6

**12V MINIATURE ROTARY TRANSFORMERS.** Output 360/310V, 30mA c.c.s. or 70mA i.c.a.s. Only 4½" x 2½" overall. Only 21/- each or £2 for 2. P. & P. 2/-

**MULTI-WAY CABLE.** ¾" diam. 7 coded wires. Ideal for inter-chassis connections or beam control. 1/3 per yard. Ditto, 10-way (5 pairs). Screened and plastic covered, 2/- per yard. P. & P. min. 1/6

**DUAL RANGE VOLTMETERS.** 0-5V and 0-100V, moving coil, 1,000Ω/V; ranges easily extended. Complete with leads and prods; solid leather carrying case 6½" x 5" x 2¼". A gift at 25/-, post free

We stock the full range of **Denco, Repanco and Eddystone coils and components**, and the most comprehensive range of **Hi-Fi equipment in the Midlands, including Quad, R.C.A., W.B., Leak, Rogers.**

### ABSORPTION WAVEMETERS.

3.00 to 35.00 Mc/s in 3 switched bands, 3.5, 7, 14, 21 and 28 Mc/s. Ham bands marked on scale. Complete with indicator bulb. A must for any ham shack. Only 17/6 each, post free

**100 kc/s CRYSTALS.** American makes, in 3-pin based holder. New condition, worth £310.0. Our price only 25/-, post free

### SPECIAL OFFER!

Due to a fortunate purchase we are able to offer these amazing

#### MINIATURE

#### ROTARY CONVERTERS

at a new Low Price.

12/6 each or 22/6 per pair  
Size 4½" x 2½" overall. 12V input. 360V 30mA Cont. or 310V 70mA Intermit. output. P. & P. 1/6.

**CHOKES.** 2.5mH, 120mA R.F. chokes. Pie wound. 2/- each. Three or more—post free

**NATIONAL TYPE R-300U Pillar Mounting R.F. Choke,** 1mH 300mA, 3/- each or 6 for 15/-

PLEASE PRINT YOUR NAME AND ADDRESS

## CHAS. H. YOUNG LTD Dept. 'R',

110 DALE END BIRMINGHAM 4 Telephone Central 1635

### SHADED POLE MOTORS.

For Tape Recorders or Gram. Units. 2 Types, Clock and Anti-clock 200/250V 50 c. 15/- each or 27/6 per pair. P. & P. 2/-

### RACK MOUNTING PANELS

19" x 5¼", 8¼" or 10½" black crackle finish, 5/9, 6/6, 7/6, 9/- respectively. P. & P. 2/-

### AERIAL EQUIPMENT

**COPPER WIRE** 14g. h.d.: 140' 17/-; 70' 8/6; 7/25 stranded; 140' 10/-; 70' 5/- plus 2/- P. & P.

**RIBBED GLASS INSULATORS.** 3" 1/6 each or 6 for 7/6. P. & P. 1/6

**TWIN FEEDER.** 300 ohm twin ribbon feeder, similar K25, 6d. per yard. K358 Telcon (round), 1/6 per yard. Post on above feeder and cable, 1/6 any length

Officially  
recommended  
by Collaro

#### TAPE RECORDER COILS

	Type	Price
Bias Osc.	QT9	7/6
Bias Filter	QT6	7/6
Treble Boost	QT7	27/6
Bias osc. for push-pull circuit		7/6

Also recommended types for other makes



COILS  
for the  
**NEW MULLARD**

## TAPE AMPLIFIER

## EXACTLY TO SPECIFICATION



New

Type S.M.  
Ferrite  
Core  
5/- retail

SUB-MINIATURE  
**HIGH Q COIL**  
RANGE

For  
SUPERHET-TRF  
TRANSISTOR  
CIRCUITS

**OSMOR**

(Dept.28) 418 Brighton Rd.  
South Croydon · Surrey  
Telephone Croydon 5148/9

# Build your own HI-FI

— with an  
entirely  
**NEW**  
range of  
**Hi-Fi**  
units and  
cabinets!



Imagine the pleasure of having this magnificent HI-FI equipment in its beautiful contemporary style furniture for your home . . . and experiencing an entirely new realism in sound reproduction. Yet the Emistructor Hi-Fi will save you money and give you all the *extra* fun and satisfaction of building it yourself—and being able to service and maintain it afterwards. Special instruction manuals guide you at each stage and teach you all about the equipment in simple terms as you build. No skill or experience is needed—only a few simple tools.

Emistructor equipment is made to the highest quality standards and is a product of E.M.I. Institutes Ltd.—part of a Company world famous for sound recording and reproducing equipment.

There is a wide variety of equipment and cabinets at different price levels to suit individual tastes and requirements. The range varies from a complete HI-FI installation with separate speaker enclosures to a simple all-in-one compact system for those with more modest requirements. All equipment is suitable for stereo or non-stereo reproduction of records. Full details and complete specifications will be sent with our free Brochure



Amplifier



Pre-Amplifier

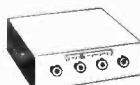

AM/FM Tuner



Tape Recorder



Record Player



Speaker System



Cabinet

**FREE BROCHURE - POST TODAY**

To: "Emistructor," (Dept. H.F. 179)  
43, Grove Park Road, London, W.4.

Please send, without obligation, details of your  
Hi-Fi equipment.

NAME .....

ADDRESS .....

IC. 136

Nov/58

## EMISTRUCTOR

Associated with one of the World's largest recording  
organisations comprising—

**"HIS MASTER'S VOICE"**

**CAPITOL · COLUMBIA**

**PARLOPHONE · MGM · ETC.**

## REPANCO HIGH GAIN COILS

DUAL RANGE CRYSTAL SET COIL, Type DRX1	...	...	...	...	...	...	...	...	2/6
DUAL RANGE COIL with Reaction, Type DRR2	...	...	...	...	...	...	...	...	4/-
MATCHED PAIR DUAL RANGE T.R.F. COILS, Type DRM3,	...	...	...	...	...	...	...	...	pair 8/-
PAIR DUAL RANGE SUPERHET COILS, Type SH4	...	...	...	...	...	...	...	...	pair 8/-
MINIATURE IRON DUST CORED COILS, Type "R":—									
Range	Aerial	H.F.	Osc.		Range	Aerial	H.F.	Osc.	
800-2,000m.	RA1	RHF1	RO1	} each 3/3	70-230m.	RA3	RHF3	RO3	} each 3/3
190-350m.	RA2	RHF2	RO2		15-50m.	RA4	RHF4	RO4	
FERRITE ROD AERIAL, Dual Range Type FR1	...	...	...	...	...	...	...	...	12/6
MINIATURE I.F. TRANSFORMERS, Type MSE (465 Kc/s)	...	...	...	...	...	...	...	...	pair 12/6
STANDARD I.F. TRANSFORMERS, Type TCG (465 Kc/s)	...	...	...	...	...	...	...	...	pair 13/6

## REPANCO EASY-TO-BUILD RECEIVERS

Constructors' Envelopes of easy wiring plans, instructions and detailed price lists of components

<b>THE HIWAYMAN</b>	Four-valve superhet Dual-range Portable using Ferrite Rod Aerial	Envelope 1/6 (post 3d.)
<b>REPANCO ONE-VALVE</b>	Beginner's Dual-range Radio Set for use with headphones	Envelope 9d. (post 3d.)
<b>REPANCO FM TUNER UNIT</b>	Using 4 EP91, 1 EB91, 1 EM80 Valves, Ratio Detector	Envelope 1/6 (post 3d.)
<b>REPANCO "THREE DEE"</b>	Dual-range Transistor Radio using 3 Transistors and Crystal Diode.	Envelope 9d. (post 3d.)
<b>REPANCO "TRANSEVEN"</b>	Amazing loudspeaker reception from 7½ volt battery supply	Envelope 1/6 (post 3d.)
<b>REPANCO "MINI-7"</b>	A new 7 Transistor superhet Portable with preset station tuning using Repanco transistor components	Envelope 1/6 (post 3d.)
<b>REPANCO "MINI-7"</b>	The amazing new transistor pocket portable radio with all the technical features of a standard receiver. Seven transistors, superhet circuit, fully tunable over medium wave. Size 5¼" x 3¼" x 1¾"	Envelope 1/6 (post 3d.)

MAIL ORDER and TRADE

### RADIO EXPERIMENTAL PRODUCTS

LIMITED  
33 MUCH PARK STREET COVENTRY  
Telephone 62572

WHOLESALE and EXPORT

### REPANCO LTD

O'BRIENS BUILDINGS  
203-269 FOESHILL ROAD COVENTRY  
Telephone 40594

## RADIOSETTE

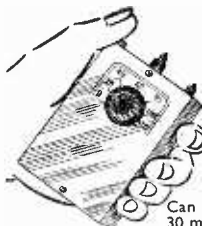

The ideal low cost transistor pocket radio for the beginner. The circuit utilises the new R.C.S. VARILoop-STICK transistor coil. A specially designed miniature 0004 tuning condenser permits the set to be in a case which fits the palm of your hand.

Can be built in 30 minutes **30/-**

All components are sold separately, full construction data including plan of parts, 2/-

## ALL-WAVE RADIO **35/-**

Ideal for the beginner or for those requiring a simple stand-by receiver

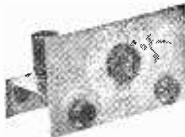

This 1 valve S.W. receiver can be built for 35/- from our list of components, which can be purchased separately. It includes valve and 1 coil covering 20-40 metres. Provision is made to increase to 2

or 3 valves if required, and all components are colour-coded so that the beginner can build this set quite easily. Send 2/- for specification, wiring diagram, layout and price list.

Postage: Under 10/-, 9d. Under 40/-, 1/6  
Over 40/-, post free

## R.C.S. PRODUCTS (RADIO) LTD

11 Oliver Road London E17 Mail Order only

## MULLARD TAPE AMPLIFIER

We stock all the items required for the Mullard Tape Amplifier described in this issue. Our fully detailed parts list sent free upon request.

**COMPLETE KITS.** Our kits are really complete and contain absolutely everything needed including nuts, bolts, wire and even solder. Every component is brand new and guaranteed to be entirely suitable in every way.

**KIT "A."** With Mullard Valves, £16.19.6. Credit Terms: Deposit £2.12.6 and seven monthly payments of £2.5.0.

**KIT "B."** With alternative valves, £15.5.0. Credit Terms: Deposit £2.8.6 and seven monthly payments of £2.0.6.

### POWER PACK KIT £4.00

**TAPE DECKS.** Send for our list of types available and details of a special offer.

**GRAMOPHONE EQUIPMENT.** Our free illustrated list details no less than 14 different types of Record changers, Single Record Players and Transcription Units.

**CREDIT TERMS** are available on anything we sell. Details and quotation for any item gladly sent.

## WATTS RADIO (Mail Order) Ltd

54 CHURCH STREET WEYBRIDGE SURREY

Telephone Weybridge 4556

NOTE: Post orders only to this address

# ANNOUNCING THE BRITISH-MADE

# Heathkit

THE  
FIRST  
MODEL  
IS THE

## 'BUILD-IT-YOURSELF' ELECTRONIC EQUIPMENT

Daystrom have great pleasure in advising readers that:

1. Their first model will be on sale from 7th November.
2. Other models will be ready shortly.
3. Upon request, information will be posted on models as available.

★ HEATHKITS WILL HELP  
TO SOLVE YOUR  
BUDGETARY  
PROBLEMS

## VALVE VOLTMETER



MODEL  
V-7A

### ABRIDGED SPECIFICATION

7 voltage ranges (A.C. & D.C.)	1.5 to 1,500V
Electronic Ohmmeter (7 ranges)	.1Ω to 1,000MΩ
Input Resistance	11MΩ
Multipliers	1% Precision Type
Circuit Board	Printed Circuit, Gold Plated
Frequency Response	±1dB, 42 c/s to 7.2 Mc/s
Meter	4 1/2" scale, 200μA movement, reading directly
D.C. & A.C. volts (RMS) & Pk to Pk)	Ohms & Decibels
INSTRUCTION MANUAL	Comprehensive construction manual for simplified assembly, operation & servicing

COMING  
SHORTLY

HI-FI STEREO  
OSCILLOSCOPE  
TRANSISTOR PORTABLE  
TRANSMITTER, ETC.

**£15.14.0**

Delivery free U.K. complete with test leads and battery. Deferred terms available. Delivery starts 7th November.

## DAYSTROM LIMITED GLOUCESTER · ENGLAND

A MEMBER OF THE DAYSTROM GROUP

THE LARGEST-SELLING ELECTRONIC KITS IN THE WORLD

## The Teletron TRANSIDYNE

6-Transistor Pocket Portable

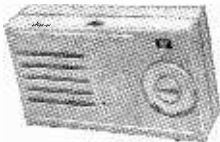

**COMPLETE KIT**  
as specified

**£11.19.6**

1/6 postage

Teletron **COMPANION** complete kit including printed circuit **£5.5.0**, postage 1/3

### ELEC-RADIO

172a BLACKSTOCK ROAD HIGHBURY  
LONDON N5 Telephone CANonbury 1672

## Res/Cap Bridge

FOR

**35/- ONLY**

P. & P. 2/-

For checking all types of resistors and condensers

**BUILT IN 1 HOUR!  
READY CALIBRATED!!**

Stamp for details of this and other instruments

**RADIO MAIL** Dept CC Raleigh Mews  
Raleigh Street Nottingham



## CONSTRUCTOR CHASSIS SERVICE

With our products the amateur can obtain that professional look

<b>MULLARD "510"</b> ready punched (except transformer holes) including base plate ... ..	18/9
Postage and packing ... ..	1/6
<b>MULLARD "TYPE C" TAPE AMPLIFIER</b> ready punched to designer's specification with all screws and brackets ... ..	29/6
Postage and packing ... ..	1/6
<b>Power Pack Chassis</b> (not punched) ... ..	4/6
Postage and packing ... ..	1/3
<b>Control panel</b> , drilled, sprayed gold hammer and clearly lettered—stove-enamelled mild steel ... ..	7/-
Postage and packing ... ..	1/-
<b>MULLARD 2-VALVE PRE-AMP</b> , ready punched, with all screws and brackets, in aluminium ... ..	14/-
Postage and packing ... ..	1/3
<b>Control panel</b> , drilled, sprayed gold hammer and clearly lettered—stove-enamelled mild steel ... ..	7/-
Postage and packing ... ..	1/-

Other well-known designs available, details on request. All above may be obtained from your usual supplier or, if any difficulty, please write to address below

Trade enquiries invited

**BERON LTD 34 NAPIER ROAD BROMLEY KENT**

## RADIO AMATEURS . . .

get your Licence in

**Half The Usual Time!**

You must be a good Morse operator! A "slap-dash" 12 w.p.m. neither satisfies the authorities, yourself, nor your operator friends. Morse operating is an exacting art unless your training is made simple and is based on sound fundamentals. For this reason, the Candler System was invented to take the "grind" out of Code tuition, turning a tricky subject into a pleasurable pursuit.

★Send 3d. stamp for the "Book of Facts"

**CANDLER SYSTEM CO**  
(Dept. 55 RC) 52b Abingdon Rd London W8  
Candler System Company Denver Colorado U.S.A.

COME TO . . .

Open all day Sat.

**Burleigh's**

for your **"WAVEMASTER" BASIC KIT**  
72/6 plus 3/6 p. & p.

We also keep in stock suitable Diesel and Electric Motors, Receivers & Kits, Actuators & Servos, Steering Mechanisms and all requirements for a first class job

**BURLEIGH of Edgware Road Ltd.**  
303 Edgware Rd W2 Telephone PAD 8827-8-9

## PULLIN

SERIES 100 TEST SET

Completely restyled with new Diakon meter cover giving wide angle of vision and very clear scales. Carrying handle and ingenious three-position stand incorporated. Printed circuit gives a rugged accurate instrument. 21 ranges and sensitivity 10,000 ohms per volt. Full data on request.



**CASH PRICE £12.7.6**

Deposit £2.10.0 (delivery by return) and balance by nine monthly payments of £1.4.6.

### PYE MOZART FM TUNER

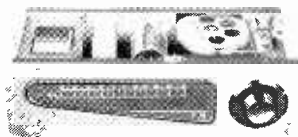

High quality tuner with own power pack. Automatic frequency control eliminates drift. Full

specification on request. Call for demonstration.

**PRICE 22 gns.**

### HOME RADIO (MITCHAM LTD)

Dept. C 187 London Road Mitcham Surrey  
Shop Hours 9-6.30 p.m. Weds. 9-1 p.m. MIT 3282

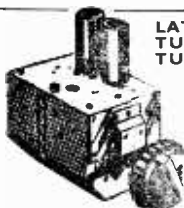

### LATEST TYPE TURRET TUNERS

Brand new stock, not surplus, with coils for Bands I and III complete with valves.

Model 1 i.f. output 33/33 Mc/s. Series heaters. Model 2 i.f. output 16/19 Mc/s. Parallel heaters. With instructions and circuit diagram, 79/6. With knobs 3/6 extra, post and ins. 2/6.

### FLUORESCENT LIGHTING KITS

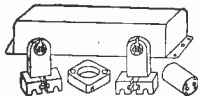

For customers wishing to use fluorescent lighting without metal work, for shop window lighting, etc., we offer complete kits of parts. Five items as illustrated comprise: best quality choke ballast, canister starter and white bakelite holders. 40 watt kit, 22/6; 80 watt kit, 26/6; plus 2/- post and ins.

### MEDRESCO HEARING AID

As supplied by National Health, completely overhauled and in good working order with six months' guarantee. Only £3.15.0 plus 2/6 post and ins. Complete with earphone and new ear plug but not batteries, these can be supplied as an extra for 5/- per set. Superior model, new, higher gain and self-contained batteries, £10.10.0, or 10/- deposit and 22 weekly payments of 10/-.



### A.C./D.C. MULTIMETER KIT



Ranges: D.C. volts 0-5, 0-50, 0-100, 0-500, 0-1,000. A.C. volts 0-5, 0-50, 0-100, 0-500, 0-1,000. D.C. milliamps 0-5, 0-100, 0-500. Ohms 0-50,000 with internal batteries. 0-500,000 with external batteries. Measures a.c./d.c. volts, d.c. current and ohms.

All the essential parts including metal case, 2" moving coil meter, selected resistors, wire for shunts, range selector, switches, calibrated scale and full instructions. Price 19/6 plus 2/6 post and ins.

### PULLIN SERIES 100 TEST SET

Undoubtedly a most useful instrument by a firm long famous for fine instruments. Entirely redesigned, it has a square movement with diacon plastic cover; this makes for a brighter, more readable scale, extra scale length and wider angle of vision. With the test set is included a pair of combined test prods and crocodile clips also a stand for inclining the meter at the best reading position. Ranges: a.c. volts: 0-10, 0-25, 0-100, 0-250, 0-500, 0-1,000; ditto d.c. A.C. current: 0-100mA; d.c. current: 0-2.5, 0-10, 0-100, 0-500 mA. Resistance: 0-1M and 0-10kΩ. Price £12.7.6 plus 5/- carr. and ins. or £1 deposit and 24 weekly payments of 10/-. **FREE GIFT.**—All purchasers this month will receive a Series 100 range extender scale and data, which adds capacity 0-0.1μF in two ranges, inductance, E.H.T., and many others.

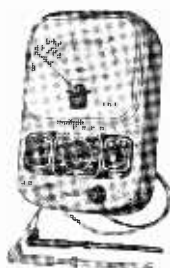

### THIS MONTH'S SNIP

Stereo Amplifier outfit, comprising 8 watt twin channel amplifier for a.c. mains working and two 8" p.m. speakers on veneered and polished corner baffles. Whole outfit giving really terrific reproduction and amazing 3D effects, £14 complete, plus carriage and insurance. Or £1 down and 28 weekly payments of 10/-.

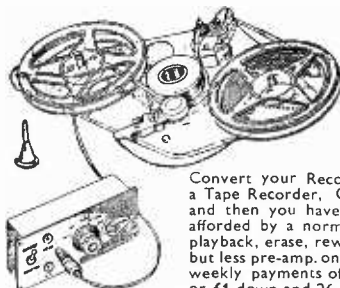

### GRAM INTO TAPE RECORDER

Convert your Record Player or Radiogram into a Tape Recorder. Can be fitted in a few seconds and then you have immediately all the facilities afforded by a normal tape recorder, i.e. record, playback, erase, rewind, etc. As illustrated. Price, but less pre-amp. only £7.10.0, or 10/- down and 16 weekly payments of 10/-. With pre-amp, £13.2.6, or £1 down and 26 weekly payments of 10/-.

### Build this 17" TV for 22 guineas

This is a very modern circuit and when you have completed it it will be equal to any factory-made model. Note these special features:

- ★ Miniature valves and metal rectifier
- ★ 12 channel turret tuner
- ★ Ferrox E.H.T. and scan coils
- ★ A.G.C. and A.V.C.

Supplied in component form with all metal work prepared and supplied with pictorial layout and theoretical wiring diagram (these are available separately price 3/6). Total cost is only £23.2.0.

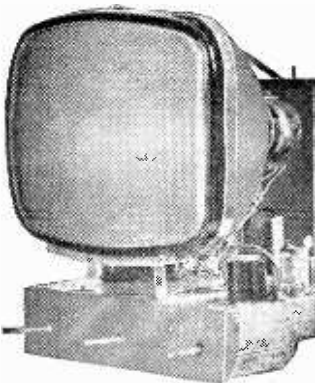

### ELECTRONIC PRECISION EQUIPMENT LTD

For prompt attention post orders should be sent to our Eastbourne address marked Dept. 34

42/46 Windmill Hill  
Ruislip Middlesex  
Telephone RUslip 5780  
Half-day Wednesday

66 Grove Road  
Eastbourne  
Sussex  
Half-day Saturday

29 Stroud Green Road  
Finsbury Park N4  
Telephone ARchway 1049  
Half-day Thursday

266 London Road  
Croydon  
Telephone CRoydon 6558  
Half-day Wednesday



# P. P. COMPONENTS LTD

(DEPT. C11) 219 ILFORD LANE ILFORD

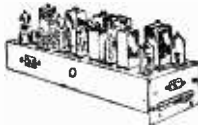

**S/VISION STRIP, 10/6.** Takes 6 EF91, 1 6D2, 1 6F14 (valves extra). Not tested. P. and p. 2/6  
**S/VISION STRIP, 25/6.** PLESSEY. S/hect. Takes 6 6F1, 2 6D2 (valves extra). I.F.s 10-14 Mc/s. Please state channel. P. and p. 2/6

**TIME BASE, 7/9.** With scanning coil, focus unit, line trans. Aluminium chassis. Less valves. Free drawing. P. and p. 3/6

**POWER PACK AND AMPLIFIER, 19/6.** A unit in every workshop. Smoothed h.t. 325V 250mA. L.T.s 4V, 6.3V and 4V centre tapped. P. and p. 3/9

**MODULATOR 165, 8/9.** Will give 10 watts audio. Contains mod. trans., class B driver trans., mic. trans. and a host of conds., resist., etc. Ideal for a low power TX modulator. Less valves. Carr. 3/6. Valves 5, 28/9 extra

**MAINS POWER TRANS., 15/6.** 350-0-350V 250mA. 6V heaters at 5A, 4V at 5A, 4V at 5A isolated. Prim. 200-250V. Drop through type. 4½" x 5" x 5". P. and p. 3/9

**MAINS POWER TRANS., 12/6.** 350-0-350V 250mA. 22V at 0.3A, 6.3V at 4A, 6.3V at 0.08A, 4V centre tapped. P. and p. 3/9

**MAINS TRANSFORMER, 12/9.** 350-0-350V 250mA. 6.3V at 5A, 4V at 4A, 4V at 7A, 4V centre tapped at 1A. Prim. 200-250V 50 cycles. P. and p. 3/9

**HEATER TRANS. 1/9.** 4V to 6V at 3A. P. & p. 1/-  
**O.P. TRANS. 1/3.** Std. matching 2-5 ohms. P. and p. 1/-, 20 for £1. P. and p. 5/6

Stamp for FREE Catalogue. U.K. only

ESSEX Telephone ILF 0295

## RECORD CASES

In leatherette, various colours. Keeps your records as new. Easy to transport when going to record sessions or parties. Hinged top, plated clip fasteners. Numbered index. Ideal gift.

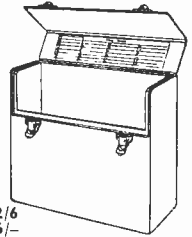

Size 12" holding 25 records 32/6  
 Size 12" holding 40 records 46/-  
 Size 7" holding 25 records 31/-  
 Size 7" holding 40 records 32/6  
 P. and p. 2/6 extra

## SPEAKER SALE. 8" P.M.



8/9. For extension to kitchen, workshop, garage, etc. Work while you listen to your favourite programme. With o.p. trans. 10/-, P. and p. 2/9 5/9. A bargain offer, but limited quantity of these modern speakers. All tested and "money back guarantee." They have a slight cone

fault, which is repaired. Not affecting the quality. P. and p. on one 2/9, on two 3/6

**EXTENSION SPEAKER, 29/9.** Fitted in attractive cabinet with flex and switch. Makes an ideal present or keeps the lady of the house happy. Ins. carr. 3/6

**FOCUS MAGNETS, 3/9.** 35mm. Permanent magnet. Salvage. P. and p. 1/9

**FOCUS MAGNETS, 5/9.** Elac. 35-38mm. Permanent magnet. Salvage. P. and p. 1/9

**ELAC FOCUS MAGNET, 12/9.** New. 35-38mm. P. and p. 1/9

Are You Servicing

## RADIO & TV RECEIVERS?

If so you can save time and trouble by dealing with a Wholesaler who specialises in stocking the components of the following manufacturers:—

- A. H. Hunt (Capacitors) Ltd.
- McMurdo Valveholders
- Colvern Potentiometers
- Lab Resistors and Ceramicaps
- T.S.L. Resistors, Speakers, etc.

Trade Catalogue on request

## KENDALL & MOUSLEY LTD

Trenoweth House Melville Road  
 Edgbaston Birmingham 16

## REVAUUMED TV TUBES

SIX MONTHS STRAIGHT GUARANTEE

Mullard		Mazda	
14" MW 36-22	£5.10.0	14" CRM 141	£5.10.0
14" MW 36-24	£5.10.0	14" CRM 142	£5.10.0
14" MW 36-44	£5.10.0	14" CRM 143	£5.10.0
14" AW 36-21	£5.10.0	15" CRM 153	£6.10.0
17" MW 43-43	£7.10.0	17" CRM 171	£7.10.0
17" MW 43-64	£7.10.0	17" CRM 172	£7.10.0
17" MW 43-69	£7.10.0	21" CRM 211	£10.10.0
21" MW 53-20	£10.10.0	21" CRM 212	£10.10.0
21" MW 53-80	£10.10.0		
		Brimar	
		14" C14BM	£5.10.0
		14" C14FM	£5.10.0
		17" C17BM	£7.10.0
		17" C17FM	£7.10.0
		17" C17JM	£7.10.0

14" Marconi, Emitron, Ferranti, G.E.C. £5.10.0  
 17" Marconi, Emitron, Ferranti, G.E.C. £7.10.0

Carriage and Insurance 12/6 (U.K.) Cash with order  
 Personal Callers Welcome

## VIDIO REPLACEMENT CO

HALES STREET DEPTFORD HIGH STREET  
 LONDON SE8

Telephone TIDeway 4506

No connection with any firms of a similar name

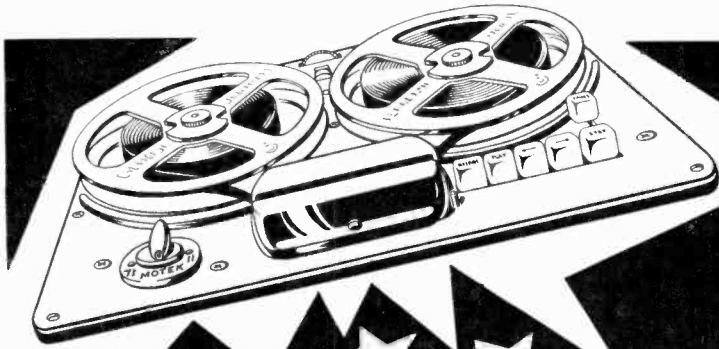

# M O T E K

## The Five Star Tape Deck

The safety record button is only one of the features which keeps the famous MOTEK tape-deck way out ahead. It is designed especially to combine all that is best with the minimum of maintenance. Illustrated literature on request. Patents Pending.

List 21 gns.

### MODERN TECHNIQUES

WEDMORE STREET LONDON N.19

Telephone : ARCHway 3114

★ VALVES		NEW TESTED AND GUARANTEED		★			
1R5	7/6	6X4	7/6	DK91	7/6	EF92	5/6
1S5	7/6	6X5G	6/-	DK92	9/-	EL41	10/-
1T4	6/-	12AH8	9/6	DK96	9/-	EL84	9/-
354	7/6	12A7	7/6	DL92	7/6	EL91	7/6
3V4	8/-	12AU7	7/6	DL94	8/-	EY51	10/6
5U4G	6/-	12AX7	9/-	DL96	9/-	EZ35	8/-
5Z4G	9/-	12K8GT13/6	EB91	5/6	EZ40	8/-	
6AM6	6/9	12K7GT	8/6	EBC41	8/-	EZ80	8/-
6AL5	5/6	12Q7GT	7/-	EBF80	9/6	EZ81	8/6
6AT6	7/6	25A6G	10/6	ECC81	7/6	KT33C	9/6
6BA6	8/6	25L6GT	7/6	ECC82	7/6	PCF82	11/-
6BE6	7/6	35Z4GT	8/6	ECC83	7/6	PL82	10/6
6BR7	10/6	35L6GT	9/6	ECC84	8/6	PY81	8/-
6BW6	8/6	53KU	11/6	EFC82	11/-	PCC84	9/-
6J5G	5/6	807	6/9	ECH81	10/6	PCF80	9/6
6J7GT	8/6	5763	10/6	ECH42	10/-	U76	8/6
6K7G	2/6	DAF91	7/6	ECL80	12/6	UBC41	10/-
6K8G	7/6	DAF96	9/-	EF36	7/6	UCH42	9/-
6Q7G	8/6	DF91	7/6	EF39	5/6	UF41	10/-
6SL7GT	8/-	DF96	9/-	EF41	9/-	UL41	9/6
6SN7GT	8/6	DH76	8/6	EF80	8/-	UY41	8/-
6V6G	7/6	DH77	7/6	EF91	6/9	W76	8/6

C.R.T. Isolation Transformers with nil, 25% and 50% boost, low capacity a.c. mains 200/250V for 2V, 4V, 6.3V and 13V tubes. All 10/6 each

Valveholders. 4, 5, 7 pin English and U.S.A. B7G, B9A, 1.0 Mc. B8G, 9d. each; B7G, B9A with screening can. 1/6; B12A, 1/3. Aladdin formers 1/4" with core, 8d. each

Scotch Boy Recording Tape, 1,200ft reels, 27/- Jack Plugs, miniature standard, 3/-; Sockets 3/- 2-Gang Condensers, 0.0005 small size, 7/6

I.F. Transformers, 465 kc/s, small size, 7/6 pair

Capacitors, small mica, 5% 1pF to 100pF, 8d.; 120pF to 1,000pF, 9d.; 1,000V wkg. .01, .0015, .0025, .004, .005, 1/- each

Crystal Diodes, G.E.C., 1/6 each

Headphones, lightweight, 4,000 ohm, 16/6 pair

Ceramic Capacitors, close col. 500V for V.H.F., 9d.

Paper Capacitors, tubular, .01, 1,000V, 1/-; 0.1 to 0.5 500V, 10d.

Paper Blocks, 4 1/2", 1,000V wkg., 3/6

Rectifiers, contact cooled, 250V 50mA, 7/6; 85mA, 9/6

Reaction Condensers, .0001, .0003, .0005, 4/6 each

Heater Trans. 200/240V, 6.3V, 1.5A, 7/6

Resistors, 1/2 and 3/4 W, insulated, 4d. and 6d.; 1W, 8d. 6W W.W., 1/-; 10W, 2/-

Electrolytics. Wire ends. 25/25V, 1/6; 50/50V, 2/-; 12/50V, 9d.; 8/450V, 2/-; 16/450V, 2/9; 16/500V, 3/6;

32/450V, 4/-; 8+8/450V, 4/6; 8+16/450V, 4/6; can types: 16/450V, 3/6; 16+16/500V, 6/-; 32/500V, 6/6;

32/450V, 6/6; 20+20/450V, 4/6; 64+120/275V, 7/6

Wavechange Switches, midget: 1p 12W, 2p 6W, 3p 4W, 4p 3W, 4p 2W, long spindles, 4/6

Toggle Switches. QMB, s.p.s.t., 2/-; s.p.d.t., 3/3; d.p.s.t., 3/6; d.p.d.t., 4/-

Chokes, 80mA, 15H, 8/6; 100mA 10H, 10/6; 150mA 10H, 14/6

★ Solder, Multicore, 4d. yd; Sleeveing 2mm, 3d. yd

P. and p. 9d. to £1; 1/6 to £2, over £2 post free; C.O.D. 2/6

Matched Pairs. EL84, 23/-; 6V6G, 17/-; 6BW6, 18/-; KT33C, 19/6; KT66, 27/6; 807 14/6 pair

1R5, 1S5, 1T4, 354, 3V4, DAF91, DF91, DK91, DK92, DL92, DL94, any four, 27/6 per set

P.P. Op. Transformers. MR 3-15 ohms for EL84, 6V6, 6BW6, etc., 18/6; Op. Pen. 50mA, 5/6; 30mA, 4/6

Volume Controls. All values, long spindle, L/S 3/-, s.p. 4/-, d.p. 4/9, ext. spkr. control 3/-

W. W. Pots. Pre-set 3/-; 3W long spindle 5/6, s.p. 6/6

P.M. Speakers. 3 ohm. 5" 16/6, 6 1/2" 17/6, 8" 21/-, 10" 25/-, 12" 30/-, Bakers 12" 15 ohm 15W, 90/-

Coaxial Cable. 75 ohm 1/2" stranded, 8d. yd; semi-air spaced, 9d. yd; screen cable single and twin, 9d. yd

Coaxial Plugs 1/- each; Sockets 1/- each

R. COOPER G8BX

32 SOUTH END CROYDON SURREY CROYDON 9186

## 17" TV Chassis, Tube and Speaker £19.19.6

17" Rectangular Tube on modified chassis. Supplied as single channel chassis covering B.B.C. channels 1-5, or incorporating Turret Tuner which can be added as an extra, at our special price to chassis purchasers of 50/- giving choice of any 2 channels (B.B.C. and I.T.A.). Extra channels can be supplied at 7/6 each. Chassis size 12" x 14 1/2" x 11" less valves. Similar chassis were used by well-known companies because of their stability and reliability. With tube and speaker £19.19.6. With all valves £25.19.6. Complete and working with Turret Tuner £28.9.6. 12 months guarantee on the tubes. 3 months guarantee on the valves and chassis. Ins. carr. (including tube) 25/-



## RECORD PLAYER CABINET

Amazing offer. Latest contemporary style rexine-covered cabinet in two-tone colour scheme. Hinged, clipped lid, carrying handle. Space available for all modern amplifiers and auto-changers, etc. Store soiled. Carr. & ins. 4/6



39/6

## AMPLIFIERS

### PORTABLE AMPLIFIER Mark D.1 59/6

Brand new. Latest design with printed circuit. Dimensions 7" x 2 1/2" x 5". A.C. only. Mains isolated. 2-3 watts output. Incorporating EL84 high gain output valves. Volume and tone controls. P.P. 3/6

### PORTABLE AMPLIFIER Mark D.2 79/6

Printed circuit. Latest design. Dimensions 7" x 2 1/2" x 5". A.C. only. Mains isolated. 3-4 watts output. Incorporating the latest ECL82 triode pentode output valve giving higher undistorted output. Volume and tone control. P.P. 3/6

### PORTABLE AMPLIFIER Mark D.3 89/6

De luxe model. Printed circuit, latest design. Dimensions 7" x 2 1/2" x 5". A.C. only. Mains isolated 3-4 watts output. Incorporating the latest ECL82 triode pentode output valve giving higher undistorted output. Volume, treble and bass control. P.P. 3/6

### PORTABLE AMPLIFIER Mark D.4 69/6

Brand new. By famous manufacturer. Especially built for portable record players. Dimensions 4 1/2" x 3 1/2" x 4". A.C. only. 2 valves EL84 (as high gain output valve) and EZ80 (as rectifier). Volume and tone controls. P.P. 3/6

### COLLARO 4-SPEED AUTO CHANGERS £7.19.6

Type RC457 incorporating auto and manual control complete with studio crystal p.u. and sapphire stylus. P.P. and ins. 5/6

## ELECTRIC CONVECTOR HEATERS 99/6



Draughty corners no longer necessary. Electric convector heaters will give you a steady comfortable heat. They can be used in any part of the house where there is a plug. Don't forget—luxurious warmth at an economical price. A.C./D.C. switched for 1 or 2kW. Illuminated grille. Size 26" x 18" x 7 1/2" deep. Ins. carr. 10/6

## SUPER CHASSIS 99/6

5-valve superhet chassis including 8" p.m. speaker and valves. Four control knobs (tone, volume, tuning and w/change switch). Four w/bands with position for gram. p.u. and extension speaker. A.C. Ins. carr. 5/6

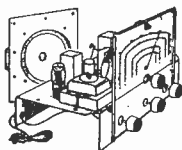

## EXTENSION SPEAKERS 29/9



Fitted with 8" P.M. speaker, W.D. or Goodmans, of the highest quality. Standard matching to any receiver (2-5 ohms). Switch and flex included. Unrepeatable at this price. Money back if not completely satisfied. Ins. carr. 3/6

Why let work interfere with your programme enjoyment when you can so cheaply relay that programme to all parts of the house with our 8" P.M. speaker, 8/9. With o.p. transformer fitted, 10/-, Post 2/9.



**SOLO SOLDERING TOOL, 12/6.** 110V or 6V (special adaptor for 200/240V 10/- extra). Automatic solder feed including a 20ft reel of Ersin 60/40 solder and spare parts. It is a tool for electronic soldering or car

wiring. Revolutionary in design. Instantly ready for use and cannot burn. In light metal case with full instructions for use. Post 2/9

## REGETTERED IMPROVED VACUUM TV TUBES

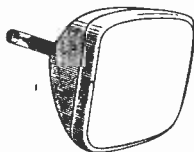

17" £7.10.0 12 MONTHS GUARANTEE 14" £5.10.0

Our 12 months guarantee (6 months full replacement, 6 months progressive) illustrates our supreme confidence in the tubes we are offering. We sell hundreds a week all over the country, as indeed we have done for the past seven years. Many of them go to the Trade, i.e. to Insurance Companies, Renters and Retailers, who are thoroughly satisfied with our supplies. Our tubes also hold a 10-day money back guarantee. 9", 10", 14", 15" & 16" ROUND TUBES. Our special offer of these sizes £5. 12" TV Tubes £6. Three months guarantee on round tubes. Ins. carr. 15/6

Send for FREE 1958 Catalogue

Liverpool St. to Manor Park Stn. 10 mins.

OPEN ALL DAY SATURDAY  
THURSDAY CLOSED 1 p.m.

TERMS AVAILABLE

**DUKE & CO** (Dept. K.11) 621/3 ROMFORD ROAD MANOR PARK E12 Telephone 1LF 6001/3

## "THE MINOR"

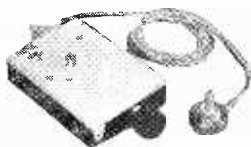

- ★ Economical (less than 1mA)
- ★ Drilled and mounted chassis
- ★ May be built within half an hour
- ★ Complete layout diagrams

- ★ Size 3" x 2" x 3/4"
- ★ Less than 2 oz weight
- ★ Variable tuning over medium waves
- ★ Three stage reflex circuit
- ★ No aerial (in areas of reasonable reception)
- ★ Easy to build

Complete set of components, including case, transistor, battery, personal earphone, **52/6** post free

All parts sold separately

Circuit diagram and shopping list **FREE**

CALL AND HEAR DEMONSTRATION MODEL  
AS DESCRIBED IN THE OCTOBER ISSUE OF THIS MAGAZINE

## "THE MAJOR"



- ★ Variable tuning over medium waveband
- ★ Home, Light and Third programmes
- ★ Internal ferrite aerial
- ★ Drilled and mounted chassis
- ★ Four-stage reflex circuit
- ★ No aerial or earth
- ★ May be assembled within an hour
- ★ Complete layout diagrams

- ★ Highly efficient
- ★ 1 1/2 mA consumption

We can supply all items, including battery, transistors, case and personal ear- **72/6** post free

All components sold separately

Circuit diagrams and shopping list **FREE**

CALL AND HEAR DEMONSTRATION MODEL  
AS DESCRIBED IN THE OCTOBER ISSUE OF THIS MAGAZINE

## — THE WORLD IN YOUR HOME —

### SHORT-WAVE RECEIVER 10-60 MC/S (5-30 Metres) RECEPTION SET TYPE 208

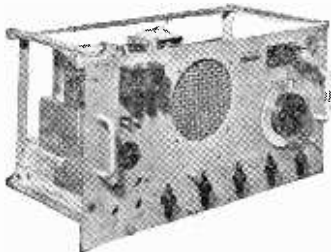

Complete with 6 valves, 2 6K8G, 2 EF39, 6Q7G and 6V6G. Internal mains power pack and 6V vibrator pack. Built-in 6 1/2" speaker. Muirhead slow-motion drive. B.F.O. and R.F. stage. I.F. freq. 2 Mc/s. Provision for phones, muting and 600 ohms. Input 110/250V a.c. 6V vibrator pack included for battery operation. All sets in new condition and air tested **£6.19.6** carr. 15/6

**NO WORK REQUIRED : JUST SWITCH ON!**

### AC/DC PORTABLE RADIO

- ★ 5 valve superhet
- ★ Built-in frame aerial
- ★ Size 10" x 10" x 4" deep
- ★ All Marconi valves
- ★ Med., long and short waveband
- ★ OR Med. and two short wavebands
- ★ Gram. sockets (for crystal or magnetic pick-ups)
- ★ 200/250 volts input
- ★ 7" x 4" elliptical speaker
- ★ Slow motion tuning
- ★ Ideal for a radio-gram.

**ONLY £7.12.6** post 7/6

Portable polished cabinet ... .. 27/6  
Super portable rexine cabinet ... .. 37/6

**ABSOLUTELY GUARANTEED BRAND NEW AND AND IN PERFECT WORKING ORDER**

### 373 MINIATURE I.F. STRIPS 9.72 MC/S



The ideal f.m. conversion unit as described in P.W., April/May, 1957. Complete with 6 valves, three EF91's, two EF92's and one EB91. I.F.T.'s etc., in absolutely new condition. With circuit and conversion data.

**12/6** (less valves)      **42/6** (with valves)

Postage and packing 2/6 (either type)

**FM AT ITS CHEAPEST!**

### CRYSTAL MIC. INSERTS

3/4" square, 3/6; 3/4" round Acos, 5/-; 1 1/2" round Acos, 7/6; 2 1/4" round Acos, 12/6. Moulded plastic hand mic. case suitable for any of above, only 2/6

### CONSTRUCTOR'S PARCEL FOR TRANSISTOR POCKET RADIO

- Perdio attractive moulded cabinet (5 1/2" x 3 1/2" x 1 1/2") ... .. 15/-
- J.B. twin gang screened 208+176pF condenser ... .. 10/-
- Perdio 2 1/2" miniature 3 ohm speaker ... .. 27/6
- Single-ended output transformer to match 10/- or, all for only 52/6 post free

**THE IDEAL BASIS FOR A MINIATURE POCKET TRANSISTOR RECEIVER**

### U.S.A. TESTMETER TYPE 834-S AC/DC 15—RANGES F.S.D. 1,000 O.P.V.

AC/DC Volts 12/60/300/600/1,200/6,000  
Milliamps 1.2/12/60/600  
Ohms 0-5,000/5 Meg. **£6.19.6**  
Complete in wooden carrying case with leads and internal batteries *Post free*

**TRANSISTOR SQUARE GENERATOR.** Complete kit with 2 Transistors, Components, Circuit and plastic case, etc. **20/-**

Send 3d. stamp for new transistor components list; new quartz crystal list; valve list; transistor receiver circuits, etc. Complete Catalogues 6d. Includes many bargains in ex-Govt. equipment

**HENRY'S RADIO LTD • 5 HARROW ROAD • LONDON W2**

At junction of Edgware Road and Harrow Road (DEPT. RCN)

Telephone PADDINGTON 1008/9

# Teletron "TRANSIDYNE" Superhet

## Six-Transistor Pocket Radio

**CAN BE BUILT FOR £11.19.6**

### SPECIAL FEATURES

- T.C.C. Printed Circuit
- Medium and Long Waves
- Internal Ferrite Aerial
- Six Transistors
- All Modern Components carded with values shown
- Rola 2½" Speaker
- Attractive Plastic Case size 6½" x 3½" x 1½"
- Powered by two No. 8 Batteries
- Complete Layout Diagrams
- Total weight 20 oz

This set is truly recommended as an ideal pocket portable containing all the latest features, giving not only simplicity in construction, but when built is really sensitive and selective, bringing in a host of foreign stations.



**ALL COMPONENTS FOR CONSTRUCTION, INCLUDING CABINET, CAN BE SUPPLIED FOR £11.19.6 P.P. 2/6**

*All parts sold separately. Send 9d. for Circuit, Plans and Prices*

**CALL & HEAR DEMONSTRATION MODEL**

**FOR THE BEST PERFORMANCE EDISWAN TRANSISTORS ARE INCLUDED AT NO EXTRA COST**

# The "TRANSISTOR - 8"

Push-Pull Portable Superhet

Entirely New Layout Diagrams Now Supplied

**TWO SETS FOR PRICE OF ONE**

**COMBINED CAR RADIO & PORTABLE**

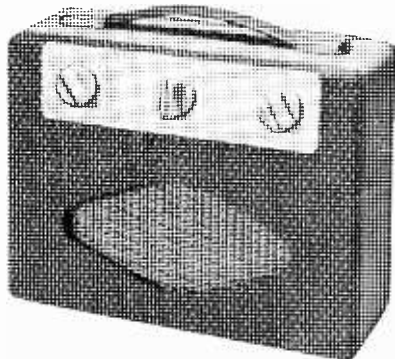

- ★ Eight transistors (7 Ediswan and 1 White Spot)
- ★ 250 Milliwatts output push-pull
- ★ Medium and long waves
- ★ Internal ferrite rod aerial
- ★ Highly sensitive
- ★ Drilled chassis 8½" x 2½"
- ★ Point-to-point wiring and practical layout
- ★ Economical. Powered by 7½V battery
- ★ Ideal as a car radio
- ★ Attractive lightweight contemporary case.

Send stamps for Instruction Booklet  
325mW version 40/- extra

All components as specified can be supplied at an inclusive price of **£11.10.0** p.p 2/6  
Car radio conversion components 8/- extra  
*All components sold separately*

**CALL AND HEAR DEMONSTRATION MODEL**

This Portable 8-Transistor Superhet is tunable for both Medium and Long Waves and is comparable in performance to any equivalent Commercial Transistor Set. Simplified construction enables this set to be built easily and quickly into an attractive lightweight cabinet supplied.

## SPECIAL OFFER—Unrepeatable Bargain

**Perdio 5-Transistor Pocket Receiver Model PRI**

- ★ Complete Medium wave coverage
- ★ Full volume speaker output
- ★ Long life on internal battery
- ★ Individually boxed

**GUARANTEED COMPLETE READY TO SWITCH ON**

Only **£8/10/0** includes battery

*p.p. 2/6*  
Not a "Do it Yourself" but a Complete Receiver  
**LIMITED QUANTITY ONLY**

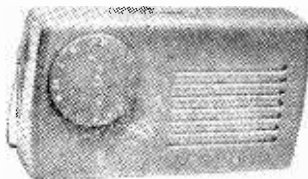

**HENRY'S RADIO LTD · 5 HARROW ROAD · LONDON W2**

Opposite Edgware Road Tube Station

(DEPT. RCN)

Telephone **PADDINGTON 1008/9**

## QUICK EFFICIENT UP-TO-DATE COMPONENT SERVICE!

### Pocket Valve Radio

Anyone can build this beautiful precision Pocket Radio in 1 hour. No knowledge whatever needed, our simple, pictorial plans take you step by step! You can't go wrong. Remarkably sensitive—covers all medium waves incl. Luxembourg, Home, Light. Size only 2" x 3" x 5 1/2".

Not a toy! but a real valve radio! Uses self-contained battery and is a really personal-phone, pocket radio with detachable rod aerial. Ideal for bedroom, garden, etc. We can supply all the parts necessary, including case, screws, easy step-by-step plans—in fact everything, for the Special Price of 39/6 plus 2/- post, etc.). **BUILD YOURS NOW!** (All parts sold separately.) Priced parts list, etc., 1/9. Big demand certain—send today! C.O.D. 2/- extra.

Can be Built for  
**39/6**



Can be Built for  
**47/6**

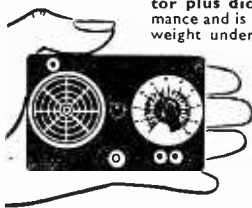

### TWO TRANSISTOR POCKET SET

Build the "Sky Pixie" Vest-pocket two-transistor plus diode radio which gives a superb performance and is highly sensitive. Size only 4 1/2" x 3 1/2" x 7/8" weight under 7oz!—yet it is a three-stage receiver covering all medium waves, working entirely off a tiny "pen-light" battery. Every part tested before despatch! Special step-by-step plans for absolute beginners. Total building cost including case, transistors, etc.—everything down to the last nut and bolt—**ONLY 47/6 with plans.** Postage, etc., 2/-, C.O.D. 2/- extra. (Parts sold separately. Priced parts list and plans 1/6.) **RUSH YOUR ORDER TODAY!**

### PRINTED CIRCUIT POCKET SET

Build this 3-transistor pocket radio... Printed Circuit Version! The "Companion" is comparable in sensitivity to a three-valve battery set; it is exceptionally small in size (4 1/2" x 3" x 1 1/2") and is a self-contained pocket radio that does not need aerial or earth. It has built-in speaker and covers medium and long waves. This unique little set can be built for **only 97/6, everything included!** (plus post and packing 2/6). All parts sold separately. Price list, etc., 6d.

## CONCORD ELECTRONICS (DEPT. RC1)

69 PRESTON STREET  
BRIGHTON 1

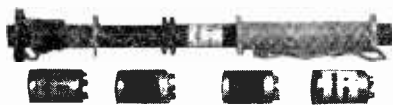

### TELETRON MINIATURE TRANSISTOR 42/-

Superhet coil kit (as illustrated)

470 kc/s I.F. Transformers and Oscillator coil in screening cans 3/8" x 1/2" dia. Dual wave Ferrite rod aerial 5 1/2" x 5/16" dia. Designed for the TRANSIDYNE miniature superhet receiver.

Descriptive folder with circuit and assembly instructions

Price 9d.

### TELETRON TYPE FX.25 15/- each

Self-tuned, dual wave Ferrite rod aerial.



### TRANSISTOR I.F. TRANSFORMERS

High Q "potted" construction with Ferrite screw cores. Mounted in screening cans 1" x 3/4" dia., 6/6 each. Oscillator coil, 6/6. Transistor type Ferrite rod aerial for MW band, 10/-.

Selective crystal diode coil type HAX, 3/- each. Type HAX.L (for LW band), 3/6. Dual wave TRF coils, type A/HF, matched pair, 7/-, with adjustable iron dust cores.

**FERRITE ROD AERIALS** Wound on high permeability Ferroxcube rod. Medium wave, FRM 4" x 5/16", 8/9. Dual wave FRD, 8" x 5/16", 12/9.

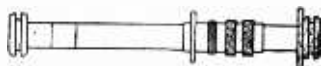

Send 5d. in stamps for complete data and circuits. All types available from advertisers in this Magazine and local component stockists

## THE TELETRON COMPANY LIMITED

112b Station Road . Chingford . London E4 Telephone SIL 0836

## SMALL ADVERTISEMENTS

Readers' small advertisements will be accepted at 3d. per word, including address, minimum charge 2/-. Trade advertisements will be accepted at 9d. per word, minimum charge 6/-. If a Box Number is required, an additional charge of 2/- will be made. Terms: Cash with order. All copy must be in hand by the 12th of the month for insertion in the following month's issue. The Publishers cannot be held liable in any way for printing errors or omissions, nor can they accept responsibility for the bona fides of advertisers.

### PRIVATE

**MULTIMETER BARGAIN.** Five ranges 15s. post free. Inductance units, 4 Philips trimmers, coils, etc., new, 4s. post free.—Young, 1 Berwick Road, London, E.17.

**FOR SALE.** "Mini-7" kit with Ardent transformers and all Mullard matched transistors. Teletron "Companion 3" kit, printed circuit with 2 Mullard and 1 Pye transistors. Addition: 2 Red/Yellow, 2 Green/Yellow transistors and diode, 75 1/4 watt resistors, 17 silver mica/ceramic, 14 electrolytics, all miniature. Ardent DI67, Repanco TT10 output transformers, Whiteley 1 1/2in speaker, balanced armature speaker. Ardent 20k ohm pot switch, 5 transistor holders. Seven potentiometers 500-250Ω. Trimmers 30, 100, 500pF. Acos mike type 17-1. Ferrite slab 5 1/2in. 13 batteries 3-1 1/2V. Pocket multi-meter. All laboratory tested, etc. (Cost over £30), £16 10s.—E. Ulmer, 7 Queens Road, Jesmond, Newcastle-on-Tyne.

**SALE.** Viewmaster valves, components, or complete chassis with valves, Channel 2, £8. Exchange Test Equipment.—45 Saxon Road, Exeter.

**PHILIPS ALL-RADIO.** cost £17, accept £7. Gent's cycle, good condition, £3.—Brar, 24 Woodville Gardens, London, W.5.

**FOR SALE.** Collaro Tape Transcriber Mk. III, £14. AVO-7 £12.—50 Lorne Gardens, London, E.11. WAN 9912.

**FOR SALE.** Trawler Band R1155, £8. Armature winding head, £10. TV (low tube), £4. Electric drill wanted. S.a.e.—18 Bishopspark Road, London, S.W.16.

**DC/AC CONVERTERS.** electronic, perfect order, 200/250V d.c. in, 230V a.c. out. 75 watts, £6; 25 watts, £4.—Bowerman, 2 Birkbeck Road, London, W.3. Telephone: ACORn 3511.

**FOR SALE.** Signal generators, valves, 26 unit, meters and other spares, cheap.—Box No. E.187.

**SUB-MINIATURE** electrolytics, 8 and 25µF, 1s. 3d. each. Many other components. S.a.e. for list.—Box No. E.188.

**FOR SALE.** Several wall projectors for 4 x 3 feet screen, fitted in contemporary leathercloth cabinets with 12 channel turret tuners, these are working, but less valves and tripler unit, £6. Complete kit including transistors for "Mini-7," £7 10s. 100-0-100µA meters, 4 1/2in calibrated in microamps 100-0-100, 30s. Carriage and postage please.—D. Bailey, 111 Hatherop Road, Hampton, Middx. Telephone: Molesey 6527.

**FOR SALE.** ITV pre-amp, new, tested, excellent results, complete with power pack, £3 10s. Mullard 3-3 amplifier, new, unused, £7 10s.—Fuller, Trailer Park, Crays Hill, Billericay, Essex.

continued on page 319

## NEW SURPLUS...

1A3	2/6	6Q7G	7/6	830B	15/-	EY51	13/6
1L4	5/-	6Q7GT	9/6	866A	15/-	EY86	13/6
1R5	7/6	6SA7M	7/6	959	5/-	EZ40	8/6
155	7/6	6SG7M	7/6	1616	5/-	EZ80	8/6
2A3	8/6	6SH7M	5/-	1629	4/-	EZ81	9/6
2X2	3/6	6SJ7M	7/6	EA50	1/6	GT1C	10/-
3A4	4/6	6SK7M	6/6	EABC8010	1/6	HK24G	25/-
3Q4	7/6	6SL7GT	7/6	EAC91	4/6	KT33C	9/6
354	8/6	6SN7GT	6/6	EAF42	1/6	PCC84	10/6
5763	12/6	6SQ7M	7/6	EB34	2/6	PCF80	13/6
5Y3G	8/6	6X4	6/6	EB91	5/6	PCF82	10/6
5Y4G	6/6	6X5GT	7/6	EBC33	7/6	PLC82	13/6
6AC7M	5/-	7B7	8/6	EBC41	10/6	PL81	15/6
6AG5	3/6	7C5	8/6	EBF80	10/-	PL82	9/6
6AK5	5/-	7C6	8/6	EBF89	10/-	PL83	10/6
6AL5	5/6	7S7	10/-	ECC82	9/6	PY80	9/6
6AM6	6/6	7Y4	8/6	ECC84	11/-	PY81	9/6
6AQ5	8/6	12A6M	7/6	ECC85	10/6	PY83	11/6
6AT6	8/-	12AT6	8/-	ECC80	12/6	R19	12/6
6AU6	8/6	12AT7	9/-	ECC82	11/6	TT11	4/-
6BBG	4/6	12AU6	9/-	ECH42	10/6	UAF42	10/6
6BA6	8/6	12AU7	8/6	ECH81	10/-	UBC41	10/6
6BE6	7/6	12BE6	8/6	ECL80	13/6	UBF89	10/6
6BH6	7/6	12CBM	7/6	ECL82	12/6	UCC85	10/-
6BJ6	7/6	12Q7GT	7/6	EF36	4/-	UCH42	10/6
6BR7	11/6	12K7GT	7/6	EF39	5/-	UCH81	10/6
6C4	5/-	12SC7M	2/6	EF41	10/6	UF41	10/6
6C5M	5/6	12SK7M	5/6	EF50	3/6	UF89	10/6
6F6M	5/6	12SQ7M	8/6	EF50(S)	4/6	UL41	10/6
6F8G	4/6	35L6GT	9/6	EF55	7/6	UY41	8/6
6J5GT	5/-	35Z4GT	7/6	EF80	9/-	UY85	8/6
6J5M	6/-	35Z5GT	8/6	EF85	10/-	UABC80	
6J6	4/-	42	7/6	EF86	15/6	UY39	9/6
6K7G	5/6	50L6GT	9/6	EF89	10/6	VR150/30	
6K8G	7/6	80	8/6	EF91	6/6		
6K8M	10/6	446A	10/6	EL32	4/-		7/6
6H6M	3/6	801A	7/6	EL41	10/-	VS70	3/-
6L6G	9/-	803	17/6	EL84	9/6	XP1.5	3/-
6L6M	10/6	808	17/6	EM80	10/6	Z77	6/6

**M.C. Meters.** 2 1/2" rd. fl. (2" dial), 0-1mA, 21/- Ditto but scaled 0-30V, 16/6. 0-500µA, 17/6

**R107 Front End.** For r.f. mix, osc. 3 bands 1.2-18 Mc (465 kc/s i.f.) with half-moon calibrated dial and slow motion drive, 40/- carr. paid

**Few only** as previously advertised, **Modulator Type 67**, new, 39/6. Indicator unit BC929A (used), 45/- carr. paid

**Miniature Hoover Rotaries**, input 12V d.c. output 310/365V 30mA. Size 4 1/2" x 2 1/2", 15/- p.p.

**Latest Model Acos Crystal Stick Microphones** MIC39-1. Frequency response flat to 6 kc/s, and within 5dB to 12 kc/s. List price £5.50. Our price 67/6 or 55/- less stand. New, boxed. Post paid

**Transistors.** Yellow/green, aud, 250mW, 7/6; OC70, 12/6; OC71, 15/-; yellow/red, r.f. to 8 Mc/s, 15/-

**Midget Mains Transformers** (same size as std. spke. o/p). Input 230/250V, o/p 220V 20mA, 6.3V 0.6A. Ditto but 175V 25mA, both types 11/9 each, post paid

**Transmitter/Receivers.** Army Type 17 Mk. 2. Complete with h.r. phones, hand mike and valves. 44-61 Mc/s. In good used condition, 29/6 each. Carr. paid. Few only. New ones 45/- each

### SPECIAL OFFER

**Performance Meters No. 2.** Comprising 230V 50 c/s mains trans. 250-0-250V 30mA, 6.3V 1 1/2A, 5V 2A (60mA h.t. may safely be drawn), 20H choke, 5Z4, Y65 magnetic eye, 2 EF50, 1 EC52, 1 EA50, dozens of components, all in smart grey louvred case 10" x 9" x 9". Made by Parmeko. Brand new and boxed. Unrepeatable component value at only 32/6 each carr. paid (U.K. only)

Post 9d. Free over £2

S.A.E. Enquiries

## JOHN ANGLIN

385 CLEETHORPE ROAD GRIMSBY LINCS  
Telephone 56315

# EDDY'S (NOTTINGHAM) LTD

(DEPT. RC) • 172 ALFRETON ROAD • NOTTINGHAM

Telephone NOTTINGHAM 74015

**B.S.R. MONARCH 4-SPEED AUTOMATIC RECORD CHANGERS.** Model UAB. Complete with high fidelity turnover head (type T8). Capacity of 10 records, 12", 10", 7", intermixed in any order. 78, 45, 33 and 16 r.p.m. For a.c. mains 100-250 volts. Special Price **£6.19.6**, post 5/-. Brand new.

**ACOS MIKE INSERTS,** 4/11 each. High quality. Can be used for tape recorders, baby alarms, musical instruments, etc. Brand new and boxed. Post 8d.

**MORSE TAPPERS.** Plated contacts, adjustable gap, heavy duty, good quality. Special price 3/6, post 9d.

**25½F 25V DC MIDGET CONDENSERS.** Size 1". 1/3 each, post 3d. Brand new.

**JACK PLUGS.** Standard type, 1/11, post 4d.

**MIDGET BATTERY ELIMINATORS.** To convert all types battery portables to mains operation, 57/6 each, post 2/6. Smaller than the batteries they replace. Size 3.7" x 2.5" x 1.8". (Please state make and model No.) Brand new and boxed.

**RECTIFIER/STABILISER.** Input voltage 150V at 10mA. For low consumption battery valves. 6/6 each. Post 6d.

**THROAT MIKES** 1/- each, post 6d. Can be used for electrifying musical instruments, etc.

**GERMANIUM CRYSTAL DIODES** 1/- each. 10/- per dozen. Post 4d.

AZ1	12/6	EBF80	9/11	KT33C	8/6	1DS	10/-	6F13	12/6	6XSGT	6/6	12K7	7/-	35A5	10/6
AZ31	12/6	EBC41	9/11	L63	6/-	1R5	7/6	6J5G	2/11	7B7	8/6	12Q7	7/6	35L6GT	9/11
CB131	22/6	ECH35	9/6	PL81	16/-	1S5	7/6	6K7G	2/11	7C5	8/-	12SH7	5/6	35W4	7/6
CCH35	22/6	EBL31	22/6	PL82	9/6	1T4	6/6	6K8G	7/6	7C6	8/-	12SK7	7/6	35Z3	13/6
CL33	17/6	ECL80	13/6	PL38	25/6	3D6	4/9	6K25	18/11	7H7	8/-	12SJ7	7/6	35Z4	7/6
CY31	12/11	EF40	13/11	PY80	8/3	5U4G	6/6	6L6G	6/11	7S7	9/11	14S7	15/6	185BT	31/11
DAF96	9/6	EF41	9/6	PY81	8/6	5Z4G	9/-	6SK7G	6/-	7Y4	7/11	19AQ5	10/6	807(B)	3/9
DF96	9/6	EF42	12/6	PZ30	18/11	6B8G	2/11	6SN7GT	5/9	10F9	9/6	20F2	25/6	807(USA)	5/6
DK96	9/6	EY51	12/6	TDD4	12/6	6BJ6	7/6	6U4G	14/6	12AH7	7/6	25A6G	12/11	95A	1/6
DL96	9/6	EY86	14/6	U801	27/11	6C4	4/9	6V6G	5/11	12AH8	9/11	25L6GT	9/11	955	3/11
DM70	7/11	EL38	25/6	UF41	8/11	6F1	13/11	6V6GT	6/6	12AT6	10/6	25Z4G	9/11	956	2/11

ANY PARCEL insured against damage in transit for only 6d. extra per order. All uninsured parcels at customer's risk.

**SURPLUS, NEW AND GUARANTEED VALVES**

All tested before despatch  
Cash with order or C.O.D. only

Postage and packing 6d. per valve extra. Over £3 Free

S.A.E. with all enquiries

## A SMALL DEPOSIT will bring you enough parts to make a complete **TRANSISTOR POCKET RADIO**

(Size 5¼ x 3¼ x 1¼) using a printed circuit

★ Send for **FREE PRICE LIST** (all parts sold separately) and/or 3/- for new simplified instruction booklet with suggested circuits and assembly details.

OUR CIRCUITS OFFER  
**HIGH SENSITIVITY**  
**HIGH SELECTIVITY**

using

R.F. Transistors **1GN.** each  
L.F. Transistors **10/-** each

all specially selected to give  
**HIGH OVERALL GAIN** with A.V.C.

**FULL MEDIUM & LONG WAVE COVERAGE**  
for as little as **£9.19.6**

- Miniature loudspeakers, only 1½" deep x 2¼" diam. **27/6**
- Miniature oscillator and i.f. coils, 1½" high, ¾" diam. **8/-**
- Jackson 00 twin gang tuning condenser with intersection screen **10/6**
- Attractive high impact polystyrene cabinet with fittings for tuner, trimmers, speaker and circuit board **12/6**

MANY OTHER SUB-MINIATURE COMPONENTS AVAILABLE

**SPECIALISED ELECTRONIC COMPONENTS LTD** 8 Eccleston Square London SW1

MAIL ORDERS ONLY



## SMALL ADVERTISEMENTS

continued from page 317

### PRIVATE—continued

**FOR SALE.** Communication receivers, BC348 (18 Mc/s—200 kc/s), £8. RMH24 (18 Mc/s—500 kc/s), £3. CR100 coil pack and condenser, £1. Television receiver, 9in., £3. VCR97, £2. Half carriage. Amateur giving up. Accessories, about 1 cwt., what offers.—15 Belgrave Close, Chelmsford, Essex.

**FOR SALE.** Eddystone 358 receiver and power pack, £10. Delivery 80 miles.—Brownlow, 1 Widdecombe Way, Bevendean, Brighton.

**NEW SWITCHED-TUNED FM UNITS** with AFC, gold hammer front panel, engraved Home, Light, Third, £10 15s. With internal power supply, £13 10s. Write for details.—Box No. E189.

**WANTED cheap.** Line O.P. Transformer for Old Age Pensioner's TV, Pye FV1; good one from old set will do.—15 Lowton Road, Golborne, Warrington.

### TRADE

**DISAPPOINTED WITH TRANSISTOR CIRCUITS? TRY MORCO REFLEX CIRCUIT** (2 transistors)—the best of its kind—loudspeaker results from indoor aerial (some districts no aerial). All parts available for Teletron "Companion" and Repanco "Mini-7" receivers. Send 8d. stamps for Notes on Transistors.—Morco Experimental Supplies, 8/10 Granville Street, Sheffield 2.

**REBUILD TUBES.** For a first-class factory rebuild (guaranteed 6 months) send, (c/f), or bring us your faulty tube with confidence (Mazda and Mullard types only). 2in, £8 10s.; 14in, £10; 17in, £12; 21in, £15. Carriage, insurance, 12s. 6d.—Enquiries s.a.c. please, or ring EAST 4837. Worland Electronic, 16 Woollett Street, Poplar, London, E.14.

**MORSE CODE TRAINING.** Special course for Beginners. Full details from (Dept. R.C.), Candler System Company, 52 Abingdon Road, London, W.8

**ILLUSTRATED CATALOGUE No. 13** containing over 450 items of Government Surplus and Model Radio Control Equipment, 2s. 2d. Refunded on purchase of goods, 2s. 6d. overseas seamount.—Arthur Sallis Radio Control Ltd., Department R.C., 93 North Road, Brighton. Telephone 25806.

**JOIN THE INTERNATIONAL S.W. LEAGUE.** Free Services to members including Q.S.L. Bureau Translation. Technical and Identification Dept.—both Broadcast and Fixed Stations, DX Certificates, contests and activities for the SWL and transmitting members. Monthly magazine, "MONITOR," containing articles of general interest to Broadcast and Amateur SWL's, Transmitter page and League affairs, etc. League supplies such as badges, headed notepaper and envelopes. QSL cards, etc., are available at reasonable cost. Send for League particulars. Membership, including monthly magazine, etc., 15s. per annum.—Secretary, ISWL, 86 Barringer Road, London, N.10.

**PANL**, recognised for many years as the unique one-coat black crackle finish. Brush applied, no baking. Available by post in 4th pint cans at 3s. 9d. from G. A. Miller, 255 Nether Street, London, N.3.

**LEARN** as you do it—we provide practical equipment combined with instructions in Radio, Television, Electricity, Mechanics, Chemistry, Photography, etc.—Write for full details to E.M.I. Institutes, Dept. RC47, London, W.4.

continued on page 320



## IN SAFETY

with AVO "PRODClips"

Patent No. 748811

Safety first every time with these patented spring-loaded AVO "Prodcips".

Cleverly designed for use as insulated prods, they are invaluable for reaching and holding test points which are difficult of access.

Post Free

**15/-**  
per pair

**AVO LTD**

Avocet House · 92-96 Vauxhall Bridge Road  
London · SW1 VICTORIA 3404 (9 lines)

## Ask "ARTHURS" First

NOTE NEW ADDRESS AT  
**125 Tottenham Court Road  
London WCI**

Close to Warren Street Station

You will have the same service and obtain all your requirements in Radio Components, Electrical Goods, Accessories and Television as previously.

Test Instruments in stock include Avo, Advance, Cossor and Taylor. List on request

VALVE MANUALS AVAILABLE

Mullard 10/6 Brimar No. 7 6/-

Osram Part 1, 2nd Edition 7/6

Post and packing 9d. each extra

**Arthurs** first  
Est. 1919

Proprietors ARTHUR GRAY LTD

**Gray House  
125 Tottenham Court Road  
London WCI**

Telephone EUSton 5802/3/4

## Forrest

Transistor Transformers  
for Quality Equipment

H. W. FORREST (TRANSFORMERS) LTD  
349, Haslucks Green Road, Shirley, Solihull,  
Warwickshire. Telephone SHlrley 2483

## NYLON • P.T.F.E

ROD BAR SHEET TUBE STRIP WIRE  
*No quantity too small List on application*

BRASS COPPER BRONZE  
ALUMINIUM LIGHT ALLOYS  
H. ROLLET & CO LTD

6 Chesham Place SW1 SLOane 3463  
Also at Liverpool Birmingham  
Manchester Leeds

LARGE STOCKS MANUFACTURERS AND  
GOVERNMENT SURPLUS EQUIPMENT  
VALVES METERS CONDENSERS  
RESISTORS TRANSFORMERS CHOKES  
SWITCHES, ETC. *Callers only. Usual shop hours.*

## N. R. BARDWELL & CO

81/83/83A SELLERS STREET SHEFFIELD 8  
Telephone 52886

## BUILD YOUR OWN TAPE RECORDER

Two-speed, twin track tape deck, kit of parts £8.5.0.  
Amplifier kit £5.18.0; Power Pack kit £2.18.0. Both  
less valves. Send for full details of these excellent kits.  
Also available made up

WISEMAN'S

21A ANCASTER ROAD BECKENHAM KENT

## HIGH FIDELITY

Quality components of all types always in stock for the  
MULLARD 2-VALVE PRE-AMPLIFIER and  
MULLARD 3-VALVE 3-WATT AMPLIFIER

Circuits free on request

510 AMPLIFIER FM TUNER	circuits 3/6
912 PLUS AMPLIFIER	" 4/-
JUPITER STEREO UNIT	" 2/6
RADIO CONSTRUCTOR FM	" 2/-
MERCURY SWITCHED FM	" 2/-
DENCO FM TUNER	" 1/6

Price list available on request

J. T. FILMER 82 DARTFORD ROAD  
DARTFORD KENT  
Telephone Dartford 4057

## INDEXES—"The Radio Constructor"

Indexes are now available for Volume  
11, August '57 to July '58 inc., price  
6d. postage 2d. A limited number of  
indexes are also available for volumes  
4, 6, 8, 9 and 10, at the same price.

DATA PUBLICATIONS LTD  
57 Maida Vale London W9

## SMALL ADVERTISEMENTS

continued from page 319

### TRADE—continued

INCORPORATED Practical Radio Engineers home  
study courses of radio and TV engineering are  
recognised by the trade as outstanding and authorita-  
tive. Moderate fees to a limited number of students  
only. Syllabus of Instructional Text is free. *The  
Practical Radio Engineer*, journal, sample copy 2s.  
6,000 Alignment Peaks for Superhets, 5s. 9d.  
Membership and Entry Conditions booklet, 1s., all  
post free from the Secretary. I.P.R.E., 20 Fairfield  
Road, London, N.8.

FREE. Brochure giving details in Home Study Training  
in Radio, Television and all branches of Electronics.  
Courses for the hobby enthusiast or for those  
aiming at the A.M.Brit.I.R.E., City and Guilds,  
R.T.E.B., with other Professional examinations.  
Train with the college operated by Britain's largest  
Electronics organisation. Moderate fees.—Write  
to E.M.I. Institutes, Dept. RC28, London, W.4.

SERVICE SHEETS for sale and hire. Radio/Tele-  
vision. S.A.E. enquiries.—J. Palmer, 32 Neasden  
Lane, London, N.W.10.

"MEDIUM WAVE NEWS," monthly during DX  
season.—Details from B. J. C. Brown, 196 Abbey  
Street, Derby.

## The Teletron TRANSIDYNE

Portable 6-Transistor Superhet  
Receiver with printed circuit

Circuit diagram with  
instructions available  
from most advertisers  
in this magazine, 1/-  
post free

## SAM MOZER LTD

288 Hedge Lane London N13

Telephone PALmers Green 1748

Sole Distributors to the Trade

# SCOTTISH INSURANCE CORPORATION LTD



62-63 Cheapside  
London EC2

## TELEVISION SETS, RECEIVERS AND TRANSMITTERS

Television Sets, Receivers and Short Wave Transmitters are expensive to acquire and you no doubt highly prize your installation. Apart from the value of your Set, you might be held responsible should injury be caused by a fault in the Set, or injury or damage by your Aerial collapsing.

A "Scottish" special policy for Television Sets, Receivers and Short Wave Transmitters provides the following cover:

- (a) Loss or damage to installation (including in the case of Television Sets the Cathode Ray Tube) by Fire, Explosion, Lightning, Theft or Accidental External Means at any private dwelling-house.
- (b) (i) Legal Liability for bodily injury to Third Parties or damage to their property arising out of the breakage or collapse of the Aerial Fittings or Mast, or through any defect in the Set. Indemnity £10,000 any one accident.
- (ii) Damage to your property or that of your landlord arising out of the breakage or collapse of the Aerial Fittings or Mast, but not exceeding £500.

The cost of Cover (a) is 5/- a year for Sets worth £50 or less, and for Sets valued at more than £50 the cost is in proportion. Cover (b) and (ii) costs only 2/6 a year if taken with Cover (a), or 5/- if taken alone.

Why not BE PRUDENT AND INSURE your installation—it is well worth while AT THE VERY LOW COST INVOLVED. If you will complete and return this form to the Corporation's Office at the above address, a proposal will be submitted for completion.

NAME (Block Letters) .....

If Lady, state Mrs. or Miss

ADDRESS (Block Letters) .....

/JB

## YOU CAN RELY ON US



### The New AVO MULTIMINOR

*A first quality pocket instrument*

Sensitivity 10,000Ω/V 0 to 1A in five ranges, 0 to 1,000V in 7 ranges. A.C. volts 0-1,000 in 5 ranges. Resistance 0-2 Meg in two ranges.

**PRICE £9.10.0** Leather Case 32/6  
or 63/4 Deposit and 6 Payments of 22/2 or 9 monthly payments of 23/3

**ALL AVO INSTRUMENTS IN STOCK**

### COSSOR HI-FI AMPLIFIER KIT

3 valve 3W, Printed Circuit, twin speaker. Beautifully kitted by Cossor Radio and Television Ltd to the last nut and bolt.

**COMPLETE KIT** or 65/- Deposit and 6 monthly Payments of 23/4  
**£9.15.0** or 23/10 Deposit and 8 monthly Payments of 23/10

82 SOUTH EALING ROAD  
LONDON W5 Tel EAL 5737

# RADIO SERVICING CO

# RADIO



# BOOKS

## DATA BOOK SERIES

- DB5 TV Fault Finding.** Profusely illustrated with photographs taken from a television screen depicting the faults under discussion, and containing a wealth of technical information, with circuits, enabling those faults to be eradicated. B.B.C. and I.T.A. 5/-, Postage 5d.
- DB6 Radio Amateur Operator's Handbook.** Contains Prefix Lists, Zone Boundaries, Call Areas, Code and Mileage Tables and much other useful operating data. 1958/9 Edition. 3/6, Postage 4d.
- DB8 Tape and Wire Recording.** A selection of articles covering both the theory and practical applications. 4th Edition. 3/-, Postage 4d.
- DB9 Radio Control for Model Ships, Boats and Aircraft.** By F. C. Judd, G2BCX. Now considered a standard work on this subject.  
Standard edition 8/6, Postage 7d.  
Clothbound edition 11/6, Postage 8d.
- DB10 Radio Control Mechanisms.** By Raymond F. Stock. The only book devoted to this subject, and complementary to DB9. 4/6, Postage 4d.
- DB11 Quality Amplifiers.** Contains a selection of popular quality amplifiers, including latest versions of the Mullard "3-3" and "5-10" 4/6, Postage 4d.

## RADIO REPRINT SERIES

- RR1 Inexpensive Car Radio** 1/6, Postage 2d.
- RR2 FM Tuner Units for Fringe and Local Area Reception.** A Jason design. 2/-, Postage 4d.
- RR3 The Argonaut AM/FM/MW/VHF Tuner Receiver.** A Jason design. 2/-, Postage 4d.
- RR4 The "Eavesdropper." 3-Transistor local station pocket receiver.** 1/6, Postage 2d.
- RR5 Mercury Switched-Tuned FM Tuner.** A Jason design. 2/-, Postage 2d.
- RR6 The Cooper-Smith B.P.I. High Fidelity 10-12 watt Amplifier and Control Unit.** 2/6, Postage 4d.
- RR7 A Versatile 2-valve Audio Pre-Amplifier.** A Mullard design. 1/-, Postage 2d.
- RR8 High-Gain Band 3 Pre-Amplifier.** 1/-, Postage 2d.
- RR9 The Jupiter Stereophonic Amplifier and Pre-amplifier.** 2/6, Postage 4d.

All available from your local bookseller, or from

## DATA PUBLICATIONS LTD

57 MAIDA VALE LONDON W9

Telegrams **Databux London**

Telephone **CUNningham 6141 (2 lines)**

Published in Great Britain by the Proprietors and Publishers

Data Publications Ltd 57 Maida Vale London W9

Printed by A. Quick & Co. (Printers) Ltd 125 High Holborn London WC1 England also at Clacton-on-Sea  
Obtainable abroad through the following Collects Subscription Service Continental Publishers & Distributors Ltd  
William Dawson & Sons Ltd Australia and New Zealand Gordon & Gotch Ltd South Africa Central News Agency  
Holland "Radio Electronica"

Registered for transmission by Magazine Post to Canada (including Newfoundland)

[www.americanradiohistory.com](http://www.americanradiohistory.com)